

# Hipot Testing of Magnetic Components



## High potential testing of insulation integrity

This application note discusses the purpose of hipot (high potential) testing and how the hipot test relates to inductor and transformer safety.

**Warning** Hipot testing involves hazardous voltages and may present a safety hazard. Always carefully follow all manufacturer's instructions for hipot test equipment.

### What is working voltage?

Working voltage, as defined by UL 60950-1, is: Highest voltage to which insulation or the component under consideration is, or can be, subjected when the equipment is operating under conditions of normal use.

### Why is the hipot test performed?

The hipot test is a Dielectric Withstand Voltage (DWV) test used to verify the capability of insulation to withstand a specified voltage without electrical breakdown. The objective is to ensure the insulation can withstand more than the expected working voltage by a sufficient margin. A hipot test can be performed on any two materials that are separated by insulation, including those separated by an air gap.

### How is the test performed?

Hipot testing is performed by applying a voltage between any two points intended to be electrically isolated, and measuring the resulting leakage current. The hipot voltage may be applied between electrical circuits and chassis ground, for example, or between primary and secondary circuits isolated by a transformer. The test waveform, whether dc or an ac sine wave is also typically specified.

### What constitutes a failure?

Hipot test failure is when the leakage current exceeds a specified limit or rapidly increases in an uncontrolled manner, or if arcing is observed. Typical leakage current limits range from 0.5 to 20 mA.

### What are typical hipot requirements for magnetic components?

Hipot test voltages are defined by the point of application, grade of insulation, anticipated environmental conditions and the safety agency standards that apply to that application. For example, UL/IEC 60950 standard typically applies to magnetic components used in telecommunications and

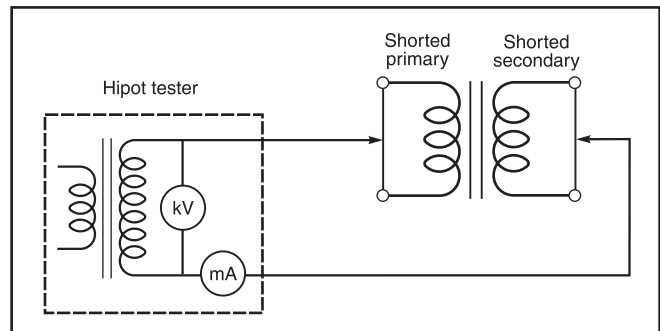

computing. Because magnetic components can be used in multiple applications involving different hazard levels, the hipot test voltage for any specific application must be carefully determined by referring to the pertinent standards for the equipment type.

Hipot voltages are chosen in order to test insulation to ensure there will be no electrical breakdown from the expected working voltage and voltage transients. A general rule of thumb for establishing the hipot test voltage is two times the working voltage + 1000 V. For a working voltage of 220 V, the rule of thumb test voltage is  $(2 \times 220 + 1000) = 1440$  V. Therefore, 1500 V is a common hipot test voltage.

Hipot test voltage may be specified as either ac or dc. Since hipot stress is generally considered to be greatest at the peak voltage of an ac waveform, ac and dc hipot test voltages are typically equated by  $V_{dc} = V_{ac(PEAK)} = V_{ac(rms)} \times \sqrt{2}$ .

Test voltage duration is usually 60 seconds, however UL and other safety standards typically allow a duration of one or two seconds for the purpose of production line testing, provided that the voltage is increased by 20% or so from the one minute test.

### What hipot tests apply to Coilcraft inductors, coupled inductors, and transformers?

Hipot testing is typically not specified for single coil inductors since they do not function to provide electrical isolation. There are many considerations in determining the safe working voltage across an inductor, as described in the Coilcraft application note [Working Voltage Ratings Applied to Inductors](#).

For coupled inductors and transformers, hipot testing is used to verify proper electrical isolation. The application

working voltage determines the hipot test voltage, which then is specified on the data sheet for each product. For core and bobbin style transformers, the schematic and hipot specification define the test voltage and test points. Most Coilcraft standard products use Functional insulation unless otherwise specified. For Functional insulation, the hipot test is typically 1500 Vrms for one minute duration for primary winding to secondary winding isolation. The test is performed with a 50 Hz or 60 Hz sine wave under controlled humidity conditions.

A winding to core (or sometimes case) hipot voltage may also be specified, and is typically lower voltage, such as 500 Vrms.

Hipot test voltages for Coilcraft transformers are typically below 5 kVrms and 6 kVdc.

### **How do safety standards relate to hipot testing?**

Coilcraft products are not usually certified as standalone items by UL, CSA, TUV, CE or other agencies. Safety standard listings generally apply to complete electronic assemblies such as power supplies, computers, modems, televisions, etc., so the hipot test for magnetics is dictated both by the safety standards and the intended application conditions.

Many Coilcraft parts are designed to meet specific UL/CSA/IEC or other standards and this information is noted on the particular Coilcraft data sheet.

### **How do the test conditions affect the outcome of the test?**

Frequency, humidity, waveform, ramp time, and duration of the voltage all may affect the outcome of a hipot test. The test should be performed in a humidity-controlled environment.

### **How does product variation affect the test results?**

The distance between points of contact as well as the dielectric properties of the insulating materials between

those points affect hipot test results. Dielectric variation is rarely cited as a cause of a failure. The safety factor involved in the hipot test is typically large enough to cover any variation in the dielectric characteristics of the insulating materials. If there is a large variation in spacing between conductors, such as wires or terminations, and this is the weakest point providing the lowest dielectric constant in the current path, the variation in hipot test results could be wide. Proper sampling techniques and statistical analysis should be followed to define any variation in the test results.

### **Is a hipot test destructive to the tested part?**

Potentially yes. Hipot testing can stress and damage the insulation if the voltage and/or duration are excessive for the specific design. Damage to insulation can be difficult to detect, so production hipot testing is a trade-off in test voltage versus possible damage to the component.

One method of determining a safe production test voltage is to test a sufficient random sample to failure by dielectric breakdown testing. The test voltage is increased until the dielectric fails, based on a leakage limit or arcing. The hipot test would then be performed at some lower voltage with a sufficient safety factor.

Care should be taken to avoid applying hipot voltage in excess of the product rating to avoid causing damage to insulation. Care must also be taken to avoid repeated testing. For repeat testing, lower voltage should be considered to avoid insulation damage.

### **References:**

[Working Voltage Ratings Applied to Inductors](#), Coilcraft Document 712, Rev. 07/25/08

Coilcraft web page: [Assistance with Safety Agency Approvals](#)

Wikipedia Article: [Dielectric withstand test](#)

UL 60950-1, March 27, 2007, ISBN 0-7629-1238-3 "Information Technology Equipment – Safety – Part 1: General Requirements" Para 1.2.9.6