

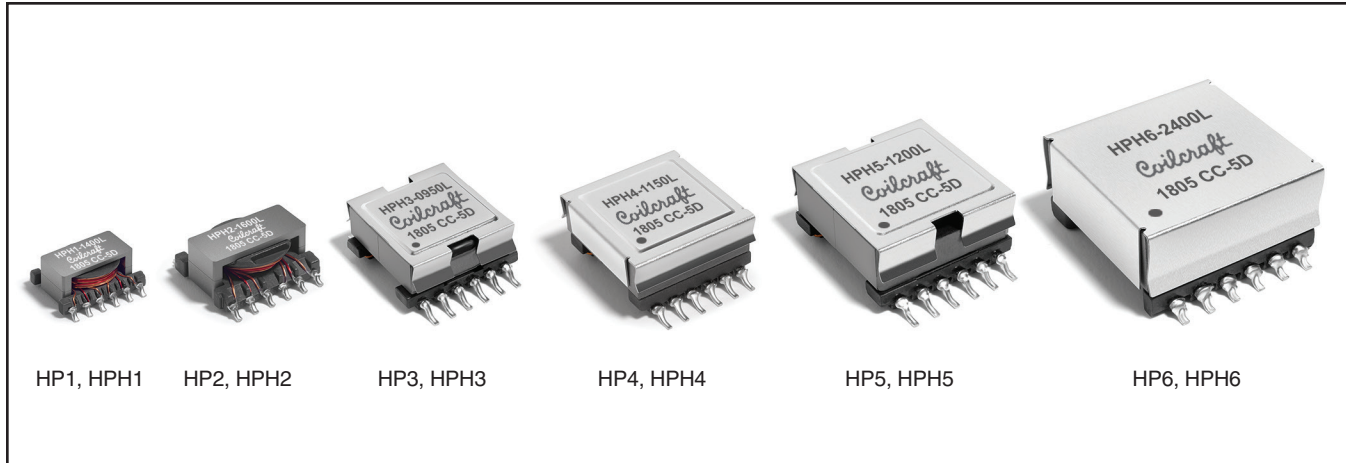

Hexa-Path Magnetics



- Six 1 : 1 isolated windings that can be connected in series or parallel
- Tightly coupled windings
- 500 Vrms, one minute isolation between each winding
- Power range: 5 – 50 Watts as inductor and flyback transformer; up to 150 Watts as forward transformer
- Frequency range up to 1 MHz
- UL1446 Class F (155°C) Insulation System (UL File E83628)

These off-the shelf parts can be used to create thousands of configurations, providing a convenient method for designers to create custom magnetics. By connecting the windings in series or parallel, the Hexa-Path components can be configured as inductors, coupled inductors and transformers for use in virtually any application: flyback, buck/boost, push-pull, forward, full and half bridge, Cuk, and SEPIC.

There are six different sizes available with five HP parts and five HPH parts in each size. The HP offers lower DCR and higher Irms ratings. The HPH offers higher inductance and greater energy storage capabilities.

Winding Layouts

HP1, HP2, HPH1, HPH2

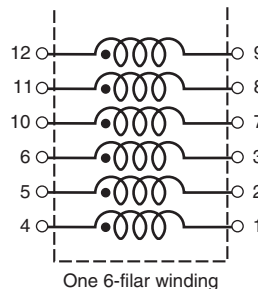

HP3, HP4, HPH5, HPH6

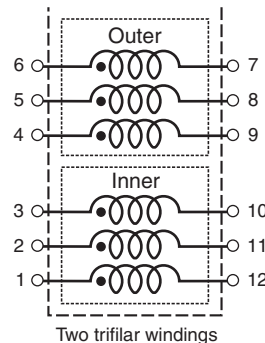

HPH3, HPH4, HPH5, HPH6

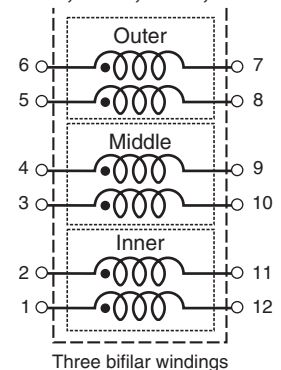



Hexa-Path Magnetics

Part number ¹	Inductance ² (µH)	DCR max ³ (Ohms)	Volt-time product ⁴ (V-µsec)	Peak energy storage ⁵ (µJ)	Isat ⁶ (A)	Irms ⁷ (A)
HP1-1400L_	89.6 ±25%	0.145	23.4	Note 8	Note 8	0.74
HP1-0190L_	12.2 ±20%	0.145	23.4	29.8	0.440	0.74
HP1-0102L_	6.5 ±15%	0.145	23.4	55.1	0.820	0.74
HP1-0076L_	4.9 ±10%	0.145	23.4	74.7	1.10	0.74
HP1-0059L_	3.8 ±5%	0.145	23.4	93.8	1.40	0.74
HP2-1600L_	78.4 ±25%	0.085	30.8	Note 8	Note 8	1.13
HP2-0216L_	10.6 ±20%	0.085	30.8	79.2	0.770	1.13
HP2-0116L_	5.7 ±15%	0.085	30.8	184	1.60	1.13
HP2-0083L_	4.1 ±10%	0.085	30.8	228	2.10	1.13
HP2-0066L_	3.2 ±5%	0.085	30.8	252	2.50	1.13
HP3-0950L_	77.0 ±25%	0.055	30.4	Note 8	Note 8	1.73
HP3-0138L_	11.2 ±20%	0.055	30.4	59.6	0.650	1.73
HP3-0084L_	6.8 ±15%	0.055	30.4	111	1.14	1.73
HP3-0055L_	4.5 ±10%	0.055	30.4	156	1.66	1.73
HP3-0047L_	3.8 ±5%	0.055	30.4	173	1.90	1.73
HP4-1150L_	93.2 ±25%	0.055	47.3	Note 8	Note 8	1.88
HP4-0140L_	11.3 ±20%	0.055	47.3	142	1.00	1.88
HP4-0075L_	6.1 ±15%	0.055	47.3	307	2.00	1.88
HP4-0060L_	4.9 ±10%	0.055	47.3	386	2.50	1.88
HP4-0047L_	3.8 ±5%	0.055	47.3	490	3.20	1.88
HP5-1200L_	76.8 ±25%	0.045	62.8	Note 8	Note 8	2.25
HP5-0155L_	9.9 ±20%	0.045	62.8	281	1.50	2.25
HP5-0083L_	5.3 ±15%	0.045	62.8	562	2.90	2.25
HP5-0067L_	4.3 ±10%	0.045	62.8	626	3.40	2.25
HP5-0053L_	3.4 ±5%	0.045	62.8	946	4.70	2.25
HP6-2400L	86.4 ±25%	0.020	87.9	Note 8	Note 8	3.50
HP6-0325L	11.7 ±20%	0.020	87.9	332	1.50	3.50
HP6-0158L	5.69 ±15%	0.020	87.9	981	3.70	3.50
HP6-0121L	4.36 ±10%	0.020	87.9	1485	5.20	3.50
HP6-0090L	3.24 ±5%	0.020	87.9	1833	6.70	3.50
HPH1-1400L_	202 ±25%	0.340	35.1	Note 8	Note 8	0.62
HPH1-0190L_	27.4 ±20%	0.340	35.1	31.1	0.300	0.62
HPH1-0102L_	14.7 ±15%	0.340	35.1	60.2	0.570	0.62
HPH1-0076L_	10.9 ±10%	0.340	35.1	99.2	0.850	0.62
HPH1-0059L_	8.5 ±5%	0.340	35.1	107	1.00	0.62
HPH2-1600L_	160 ±25%	0.155	44.0	Note 8	Note 8	0.83
HPH2-0216L_	21.6 ±20%	0.155	44.0	82.3	0.550	0.83
HPH2-0116L_	11.6 ±15%	0.155	44.0	177	1.10	0.83
HPH2-0083L_	8.3 ±10%	0.155	44.0	302	1.70	0.83
HPH2-0066L_	6.6 ±5%	0.155	44.0	333	2.00	0.83
HPH3-0950L_	160 ±25%	0.125	43.9	Note 8	Note 8	1.13
HPH3-0138L_	23.6 ±20%	0.125	43.9	52.5	0.420	1.13
HPH3-0084L_	14.2 ±15%	0.125	43.9	98.0	0.740	1.13
HPH3-0055L_	9.3 ±10%	0.125	43.9	169	1.20	1.13
HPH3-0047L_	7.94 ±5%	0.125	43.9	196	1.40	1.13
HPH4-1150L_	194 ±25%	0.078	68.3	Note 8	Note 8	1.65
HPH4-0140L_	23.7 ±20%	0.078	68.3	138	0.680	1.65
HPH4-0075L_	12.7 ±15%	0.078	68.3	314	1.40	1.65
HPH4-0060L_	10.1 ±10%	0.078	68.3	368	1.70	1.65
HPH4-0047L_	7.94 ±5%	0.078	68.3	529	2.30	1.65
HPH5-1200L_	173 ±25%	0.070	94.2	Note 8	Note 8	1.95
HPH5-0155L_	22.3 ±20%	0.070	94.2	248	0.940	1.95
HPH5-0083L_	12.0 ±15%	0.070	94.2	546	1.90	1.95
HPH5-0067L_	9.65 ±10%	0.070	94.2	700	2.40	1.95
HPH5-0053L_	7.63 ±5%	0.070	94.2	809	2.90	1.95
HPH6-2400L	194 ±25%	0.030	131.9	Note 8	Note 8	2.90
HPH6-0325L	26.3 ±20%	0.030	131.9	477	1.20	2.90
HPH6-0158L	12.8 ±15%	0.030	131.9	1176	2.70	2.90
HPH6-0121L	9.8 ±10%	0.030	131.9	1783	3.80	2.90
HPH6-0090L	7.29 ±5%	0.030	131.9	1944	4.60	2.90

1. Please specify termination and packaging codes:

HPH1-1400LD

Termination: L = RoHS compliant tin-silver over tin over nickel over phos bronze. Special order:
T = RoHS tin-silver-copper (95.5/4/0.5) or
S = non-RoHS tin-lead (63/37).

Packaging: All but HP6 and HPH6:

D = 13" machine-ready reel.
EIA-481 embossed plastic tape

B = Less than full reel. In tape, but not machine ready. To have a leader and trailer added (\$25 charge), use code letter D instead.

HP6 and HPH6: 24 per tray (no code)

2. Inductance is per winding, measured at 100 kHz, 0.1 Vrms, 0 Adc.
3. DCR is per winding, measured on Cambridge Technology micro-ohmmeter or equivalent.
4. Volt-time product is for a single winding or multiple windings connected in parallel. To calculate volt-time product for windings connected in series, multiply the value specified in the table by the number of windings connected in series.
5. Peak energy storage is for any combination of windings, assuming saturation current applied. See note 6 for definition of saturation current.
6. DC current at which the inductance drops 30% typ from its value without current, based on current applied to all six windings connected in series. For applications where all windings are not connected in series, use the following equation to calculate Isat:
$$Isat = Isat_{table} \times 6 \div \text{number of windings in series.}$$
7. Current that causes a 40°C rise from 25°C ambient due to self heating, tested with continuous current flow through all windings connected in series. Application temperature rise will depend on the operating current, duty cycle, and winding connection.
8. Part is designed exclusively for use as a forward converter transformer and was not tested for energy storage and saturation current.
9. Electrical specifications at 25°C.
Refer to Doc 362 "Soldering Surface Mount Components" before soldering

Core material Ferrite

Terminations RoHS tin-silver over tin over nickel over phos bronze. Other terminations available at additional cost.

Ambient temperature -40°C to +85°C with Irms current.

Maximum part temperature +125°C

Storage temperature Component: -40°C to +125°C.
Packaging: -40°C to +80°C

Resistance to soldering heat Max three 40 second reflows at +260°C, parts cooled to room temperature between cycles

Moisture Sensitivity Level (MSL) 1 (unlimited floor life at <30°C / 85% relative humidity)

Failures in Time (FIT) 38 per billion hours

Mean Time Between Failures (MTBF)

26,315,789 hours, calculated per Telcordia SR-332

PCB washing Tested to MIL-STD-202 Method 215 plus an additional aqueous wash. See [Doc787](#).
[PCB Washing.pdf](#).



www.coilcraft.com

US +1-847-639-6400 sales@coilcraft.com
UK +44-1236-730595 sales@coilcraft-europe.com
Taiwan +886-2-2264 3646 sales@coilcraft.com.tw
China +86-21-6218 8074 sales@coilcraft.com.cn
Singapore +65-6484 8412 sales@coilcraft.com.sg

Document 613-2 Revised 02/12/18

© Coilcraft Inc. 2018

This product may not be used in medical or high risk applications without prior Coilcraft approval. Specification subject to change without notice. Please check web site for latest information.



Hexa-Path Magnetics

HP1, HPH1

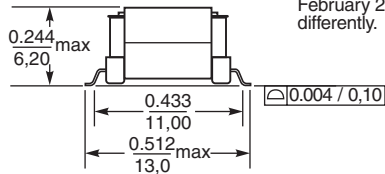
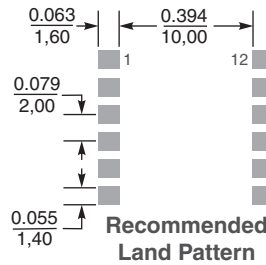
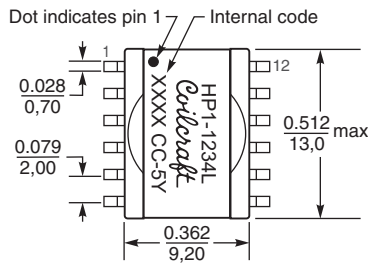

Parts manufactured prior to February 2018 may be marked differently.

Dimensions are in $\frac{\text{inches}}{\text{mm}}$

Weight: 1.4 g
Packaging 500 per 13" reel Plastic tape: 24 mm wide, 0.5 mm thick, 20 mm pocket spacing, 6.6 mm pocket depth

HP2, HPH2

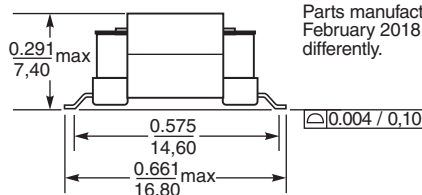
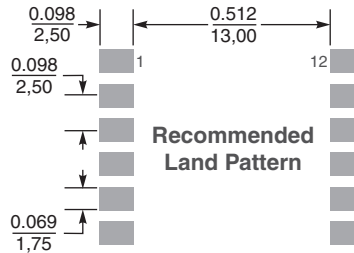
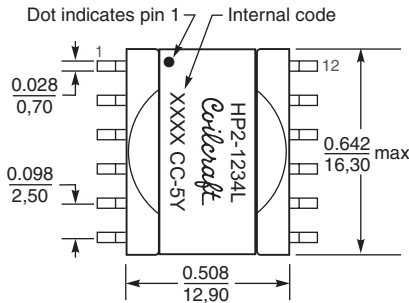

Parts manufactured prior to February 2018 may be marked differently.

Dimensions are in $\frac{\text{inches}}{\text{mm}}$

Weight: 2.7 – 2.8 g
Packaging 400 per 13" reel Plastic tape: 32 mm wide, 0.4 mm thick, 20 mm pocket spacing, 7.6 mm pocket depth



www.coilcraft.com

US +1-847-639-6400 sales@coilcraft.com
UK +44-1236-730595 sales@coilcraft-europe.com
Taiwan +886-2-2264 3646 sales@coilcraft.com.tw
China +86-21-6218 8074 sales@coilcraft.com.cn
Singapore + 65-6484 8412 sales@coilcraft.com.sg

Document 613-3 Revised 02/12/18

© Coilcraft Inc. 2018
 This product may not be used in medical or high risk applications without prior Coilcraft approval. Specification subject to change without notice. Please check web site for latest information.



Hexa-Path Magnetics

HP3, HPH3

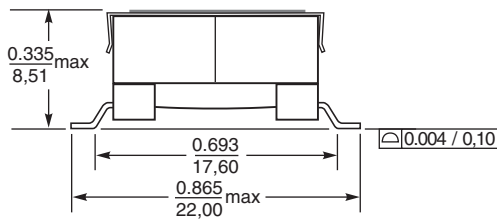
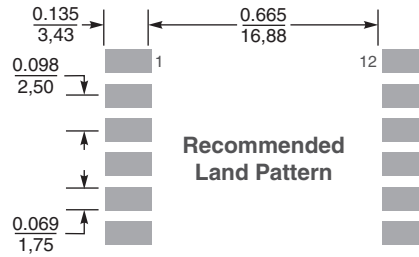
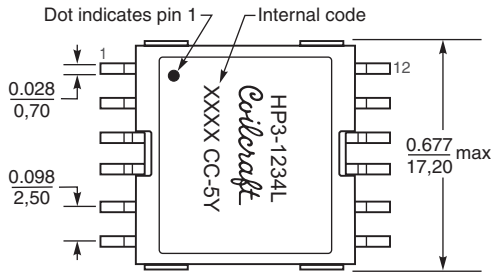

Current production parts have a metal cover. Previous production had a non-metal cover. Footprint and land pattern are the same.

Parts manufactured prior to February 2018 may be marked differently.

Weight: 4.2 – 4.6 g

Packaging 200 per 13" reel Plastic tape: 44 mm wide, 0.4 mm thick, 28 mm pocket spacing, 9.6 mm pocket depth

Dimensions are in $\frac{\text{inches}}{\text{mm}}$

HP4, HPH4

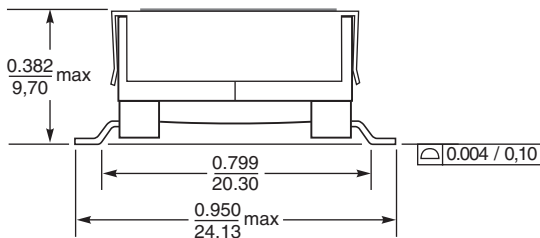
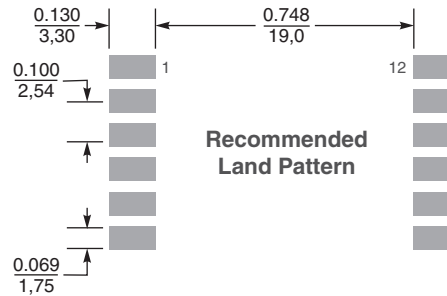
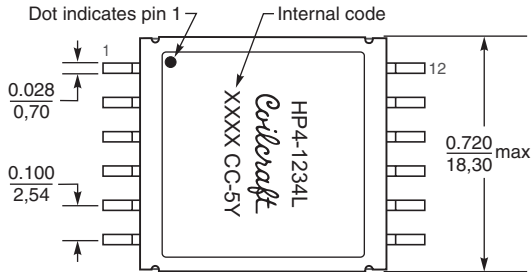

Current production parts have a metal cover. Previous production had a non-metal cover. Footprint and land pattern are the same.

Parts manufactured prior to February 2018 may be marked differently.

Weight: 6.8 – 7.5 g

Packaging 200 per 13" reel Plastic tape: 44 mm wide, 0.4 mm thick, 24 mm pocket spacing, 10.56 mm pocket depth

Dimensions are in $\frac{\text{inches}}{\text{mm}}$



www.coilcraft.com

US +1-847-639-6400 sales@coilcraft.com
UK +44-1236-730595 sales@coilcraft-europe.com
Taiwan +886-2-2264 3646 sales@coilcraft.com.tw
China +86-21-6218 8074 sales@coilcraft.com.cn
Singapore + 65-6484 8412 sales@coilcraft.com.sg

Document 613-4 Revised 02/12/18

© Coilcraft Inc. 2018

This product may not be used in medical or high risk applications without prior Coilcraft approval. Specification subject to change without notice. Please check web site for latest information.



Hexa-Path Magnetics

HP5, HPH5

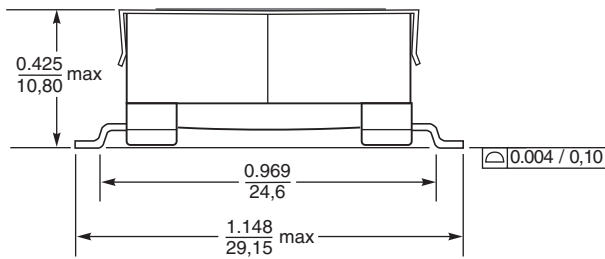
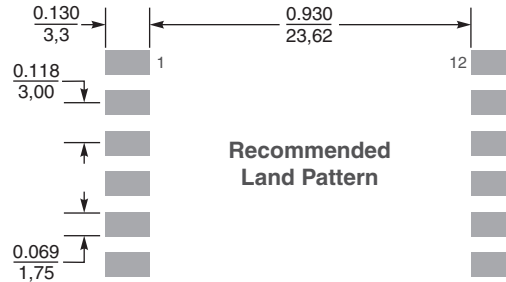
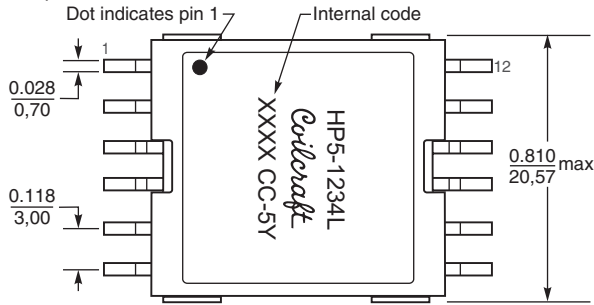

Current production parts have a metal cover. Previous production had a non-metal cover. Footprint and land pattern are the same.

Parts manufactured prior to February 2018 may be marked differently.

Weight: 10.6 – 11.5 g

Packaging 175 per 13" reel Plastic tape: 44 mm wide, 0.4 mm thick, 28 mm pocket spacing, 12.0 mm pocket depth

Dimensions are in inches / mm

HP6, HPH6

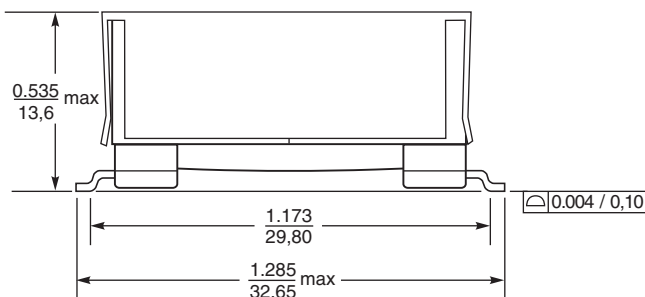
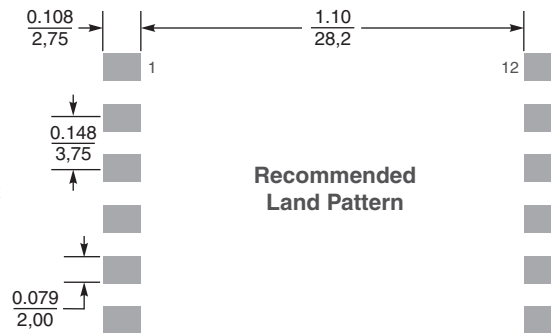
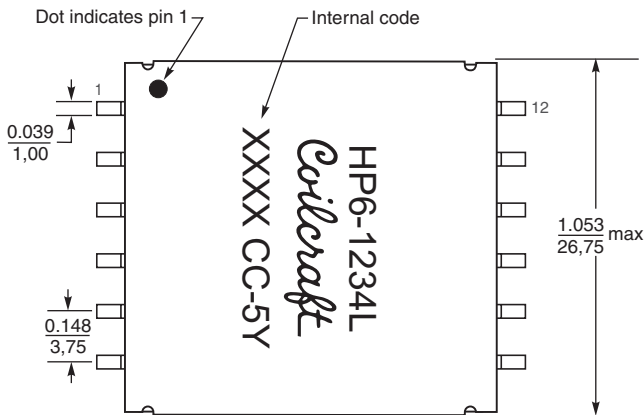

Current production parts have a metal cover. Previous production had a non-metal cover. Footprint and land pattern are the same.

Parts manufactured prior to February 2018 may be marked differently.

Weight: 22.4 – 24.3 g

Packaging 24 per tray

Dimensions are in inches / mm



www.coilcraft.com

US +1-847-639-6400 sales@coilcraft.com
UK +44-1236-730595 sales@coilcraft-europe.com
Taiwan +886-2-2264 3646 sales@coilcraft.com.tw
China +86-21-6218 8074 sales@coilcraft.com.cn
Singapore + 65-6484 8412 sales@coilcraft.com.sg

Document 613-5 Revised 02/12/18

© Coilcraft Inc. 2018

This product may not be used in medical or high risk applications without prior Coilcraft approval. Specification subject to change without notice. Please check web site for latest information.



Hexa-Path Magnetics

Formulas used to calculate electrical characteristics

Connecting windings in series

$$\text{Inductance} = \text{Inductance}_{\text{table}} \times (\text{number of windings})^2$$

$$\text{DCR} = \text{DCR}_{\text{table}} \times \text{number of windings}$$

$$\text{Isat} = (\text{Isat}_{\text{table}} \times 6) \div \text{number of windings connected in series}$$

$$\text{Irms} = \text{Irms}_{\text{table}}$$

Connecting windings in parallel

$$\text{Inductance} = \text{Inductance}_{\text{table}}$$

$$\text{DCR} = 1 \div [\text{number of windings} \times (1 \div \text{DCR}_{\text{table}})]$$

$$\text{Isat} = (\text{Isat}_{\text{table}} \times 6) \div \text{number of windings connected in series}$$

$$\text{Irms} = \text{Irms}_{\text{table}} \times \text{number of windings}$$

Inductors – using multiple windings

Part number	Inductance (μH)	DCR max (Ohms)	Volt-time product (V-μsec)	Peak energy storage (μJ)	Isat (A)	Irms (A)
HP3-0138L_	11.2 ±20%	0.055	30.4	1.656	0.650	1.73

Connecting windings in series

For higher inductance, the windings can be connected in series. As inductance increases, energy storage and Irms remain the same, but DCR increases and Isat decreases.

Example: Calculate new electricals for HP3-0138L with four windings (W_n) connected in series:

$$\begin{aligned} \text{Inductance} &= \text{Inductance}_{\text{table}} \times W_n^2 \\ &= 11.2 \times 4^2 = 179.2 \mu\text{H} \end{aligned}$$

$$\begin{aligned} \text{DCR} &= \text{DCR}_{\text{table}} \times W_n \\ &= 0.055 \times 4 = 0.22 \text{ Ohms} \end{aligned}$$

$$\begin{aligned} \text{Isat} &= (\text{Isat}_{\text{table}}) \times 6 \div W_n \\ &= (0.65 \times 6) \div 4 = 0.975 \text{ A} \end{aligned}$$

$$\text{Irms} = \text{Irms}_{\text{table}} = 1.73 \text{ A}$$

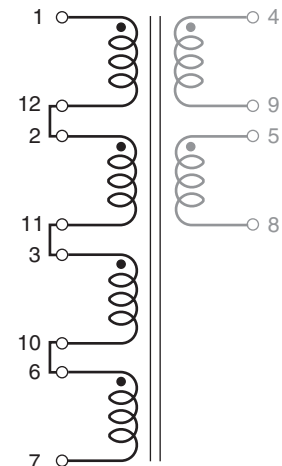

$$\begin{aligned} L &= 179.2 \mu\text{H} \\ \text{DCR} &= 0.22 \Omega \\ \text{Isat} &= 0.975 \text{ A} \\ \text{Irms} &= 1.73 \text{ A} \end{aligned}$$

Connecting windings in parallel

To increase current ratings, the windings (W_n) can be connected in parallel. DCR decreases, current ratings increase, and inductance remains the same.

Example: Calculate new electricals for HP5-0083L, with three (W_n) windings connected in parallel (equivalent to one winding in series):

$$\begin{aligned} \text{Inductance} &= \text{Inductance}_{\text{table}} \\ &= 11.2 \mu\text{H} \end{aligned}$$

$$\begin{aligned} \text{DCR} &= 1 \div [W_n \times (1 \div \text{DCR}_{\text{table}})] \\ &= 1 \div [3 \times (1 \div 0.045)] = 0.015 \text{ Ohms} \end{aligned}$$

$$\begin{aligned} \text{Isat} &= (\text{Isat}_{\text{table}} \times 6) \div W_n \\ &= (0.65 \times 6) \div 1 = 3.9 \text{ A} \end{aligned}$$

$$\begin{aligned} \text{Irms} &= \text{Irms}_{\text{table}} \times W_n \\ &= 1.73 \times 3 = 5.19 \text{ A} \end{aligned}$$

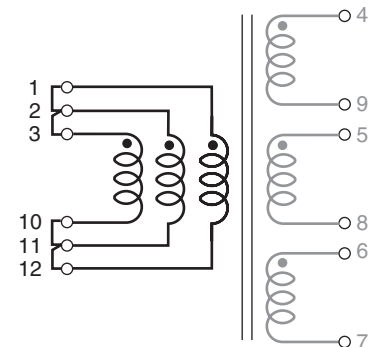

$$\begin{aligned} L &= 11.2 \mu\text{H} \\ \text{DCR} &= 0.015 \Omega \\ \text{Isat} &= 3.9 \text{ A} \\ \text{Irms} &= 5.19 \text{ A} \end{aligned}$$



Hexa-Path Magnetics

Formulas used to calculate electrical characteristics

Connecting windings in series

$$\text{Inductance} = \text{Inductance}_{\text{table}} \times (\text{number of windings})^2$$

$$\text{DCR} = \text{DCR}_{\text{table}} \times \text{number of windings}$$

$$\text{Isat} = (\text{Isat}_{\text{table}} \times 6) \div \text{number of windings connected in series}$$

$$\text{Irms} = \text{Irms}_{\text{table}}$$

Connecting windings in parallel

$$\text{Inductance} = \text{Inductance}_{\text{table}}$$

$$\text{DCR} = 1 \div [\text{number of windings} \times (1 \div \text{DCR}_{\text{table}})]$$

$$\text{Isat} = (\text{Isat}_{\text{table}} \times 6) \div \text{number of windings connected in series}$$

$$\text{Irms} = \text{Irms}_{\text{table}} \times \text{number of windings}$$

Create a 13 Watt 2 : 1 : 1 flyback transformer with a bias winding

Choose HPH3-0138L

$$V_{\text{in}} = 36 - 57 \text{ Vdc}; V_{\text{out}} = 12 \text{ V}, 1.1 \text{ A}$$

Part number	Inductance (μH)	DCR max (Ohms)	Volt-time product (V-μsec)	Peak energy storage (μJ)	Isat (A)	Irms (A)
HPH3-0138L	23.6 ±20%	0.125	43.9	1.457	0.420	1.13

Connecting primary windings in series

When primary windings (W_{pri}) are connected in series, inductance increases, energy storage and Irms remain the same, but DCR increases and Isat decreases.

Example: For HPH3-0138L, connect two primary windings in series:

$$\begin{aligned} \text{Inductance} &= \text{Inductance}_{\text{table}} \times W_{\text{pri}}^2 \\ &= 23.6 \times 2^2 = 94.4 \mu\text{H} \end{aligned}$$

$$\begin{aligned} \text{DCR} &= \text{DCR}_{\text{table}} \times W_{\text{pri}} \\ &= 0.125 \times 2 = 0.25 \text{ Ohms} \end{aligned}$$

$$\begin{aligned} \text{Isat} &= (\text{Isat}_{\text{table}} \times 6) \div W_{\text{pri}} \\ &= (0.42 \times 6) \div 2 = 1.26 \text{ A} \end{aligned}$$

$$\text{Irms} = \text{Irms}_{\text{table}} = 1.13 \text{ A}$$

Connecting secondary windings in parallel

When secondary windings (W_{sec}) are connected in parallel, DCR decreases and Irms increases.

Example: For HPH3-0083L, connect two secondary windings in parallel:

$$\begin{aligned} \text{DCR} &= 1 \div [W_{\text{sec}} \times (1 \div \text{DCR}_{\text{table}})] \\ &= 1 \div [(2 \times (1 \div 0.125))] = 0.0625 \text{ Ohms} \end{aligned}$$

$$\text{Irms} = \text{Irms}_{\text{table}} \times W_{\text{sec}} = 1.13 \times 2 = 2.26 \text{ A}$$

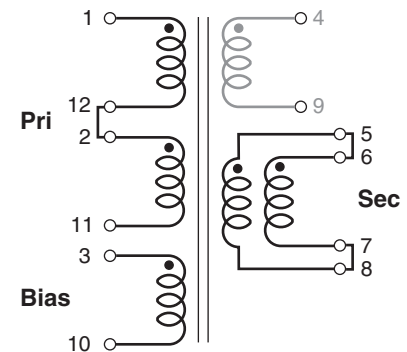

Primary:

L = 94.4 μH
DCR = 0.25Ω
Isat = 1.26 A
Irms = 1.13 A

Secondary:

DCR = 0.0625Ω
Irms = 2.26 A



Hexa-Path Magnetics

Formulas used to calculate electrical characteristics

Connecting windings in series

$$\text{Inductance} = \text{Inductance}_{\text{table}} \times (\text{number of windings})^2$$

$$\text{DCR} = \text{DCR}_{\text{table}} \times \text{number of windings}$$

$$\text{Isat} = (\text{Isat}_{\text{table}} \times 6) \div \text{number of windings connected in series}$$

$$\text{Irms} = \text{Irms}_{\text{table}}$$

Connecting windings in parallel

$$\text{Inductance} = \text{Inductance}_{\text{table}}$$

$$\text{DCR} = 1 \div [\text{number of windings} \times (1 \div \text{DCR}_{\text{table}})]$$

$$\text{Isat} = (\text{Isat}_{\text{table}} \times 6) \div \text{number of windings connected in series}$$

$$\text{Irms} = \text{Irms}_{\text{table}} \times \text{number of windings}$$

Create a 130 Watt, 1 : 1, two switch forward converter transformer

Choose HPH6-2400L

$$V_{\text{in}} = 36 - 57 \text{ Vdc}; V_{\text{out}} = 12 \text{ V}, 10.8 \text{ A}$$

Part number	Inductance (μH)	DCR max (Ohms)	Volt-time product (V-μsec)	Peak energy storage (μJ)	Isat (A)	Irms (A)
HPH6-2400L	194 ±25%	0.030	131.9	N/A	N/A	2.90

Connecting primary windings in parallel

When primary windings (W_{pri}) are connected in parallel, DCR decreases, Irms increases, and inductance and volt-time product remain the same.

Example: For HPH6-2400L, connect three primary windings in parallel:

$$\begin{aligned} \text{Inductance} &= \text{Inductance}_{\text{table}} \\ &= 194 \mu\text{H} \end{aligned}$$

$$\begin{aligned} \text{DCR} &= 1 \div [W_{\text{pri}} \times (1 \div \text{DCR}_{\text{table}})] \\ &= 1 \div [(3 \times (1 \div 0.030))] = 0.010 \text{ Ohms} \end{aligned}$$

$$\begin{aligned} \text{VT} &= \text{VT}_{\text{table}} \\ &= 131.9 \text{ V-}\mu\text{sec} \end{aligned}$$

$$\begin{aligned} \text{Irms} &= \text{Irms}_{\text{table}} \times W_{\text{pri}} \\ &= 2.90 \times 3 = 8.70 \text{ A} \end{aligned}$$

Connecting secondary windings in parallel

When secondary windings (W_{sec}) are connected in parallel, DCR decreases and Irms increases.

Example: For HPH6-2400L, connect three secondary windings in parallel:

$$\begin{aligned} \text{DCR} &= 1 \div [W_{\text{sec}} \times (1 \div \text{DCR}_{\text{table}})] \\ &= 1 \div [(3 \times (1 \div 0.030))] = 0.010 \text{ Ohms} \end{aligned}$$

$$\begin{aligned} \text{Irms} &= \text{Irms}_{\text{table}} \times W_{\text{sec}} \\ &= 2.90 \times 3 = 8.70 \text{ A} \end{aligned}$$

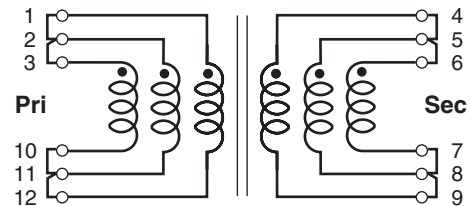

Primary:

$$\begin{aligned} L &= 194 \mu\text{H} \\ \text{DCR} &= 0.01\Omega \\ \text{Irms} &= 8.7 \text{ A} \\ \text{VT} &= 131.9 \text{ V-}\mu\text{sec} \end{aligned}$$

Secondary:

$$\begin{aligned} \text{DCR} &= 0.01\Omega \\ \text{Irms} &= 8.7 \text{ A} \end{aligned}$$



Hexa-Path Magnetics

Formulas used to calculate electrical characteristics

Connecting windings in series

$$\text{Inductance} = \text{Inductance}_{\text{table}} \times (\text{number of windings})^2$$

$$\text{DCR} = \text{DCR}_{\text{table}} \times \text{number of windings}$$

$$\text{Isat} = (\text{Isat}_{\text{table}} \times 6) \div \text{number of windings connected in series}$$

$$\text{Irms} = \text{Irms}_{\text{table}}$$

Connecting windings in parallel

$$\text{Inductance} = \text{Inductance}_{\text{table}}$$

$$\text{DCR} = 1 \div [\text{number of windings} \times (1 \div \text{DCR}_{\text{table}})]$$

$$\text{Isat} = (\text{Isat}_{\text{table}} \times 6) \div \text{number of windings connected in series}$$

$$\text{Irms} = \text{Irms}_{\text{table}} \times \text{number of windings}$$

Create a 100 Watt, 1 : 2, half bridge forward converter transformer with center tapped secondary

Choose HP6-2400L

$$V_{\text{in}} = 36 - 57 \text{ Vdc}; V_{\text{out}} = 24 \text{ V}, 4.2 \text{ A}$$

Part number	Inductance (μH)	DCR max (Ohms)	Volt-time product (V-μsec)	Peak energy storage (μJ)	Isat (A)	Irms (A)
HPH6-2400L	194 ±25%	0.030	131.9	N/A	N/A	2.90

Connecting primary windings in parallel

When primary windings (W_{pri}) are connected in parallel, DCR decreases, current ratings increase, and inductance and volt-time product remain the same.

Example: For HPH-2400L, connect two primary windings in parallel:

$$\begin{aligned} \text{Inductance} &= \text{Inductance}_{\text{table}} \\ &= 194 \mu\text{H} \end{aligned}$$

$$\begin{aligned} \text{DCR} &= 1 \div [W_{\text{pri}} \times (1 \div \text{DCR}_{\text{table}})] \\ &= 1 \div [(2 \times (1 \div 0.030))] = 0.015 \text{ Ohms} \end{aligned}$$

$$\begin{aligned} \text{VT} &= \text{VT}_{\text{table}} \\ &= 131.9 \text{ V-}\mu\text{sec} \end{aligned}$$

$$\begin{aligned} \text{Irms} &= \text{Irms}_{\text{table}} \times W_{\text{pri}} \\ &= 2.90 \times 2 = 5.8 \text{ A} \end{aligned}$$

Connecting secondary windings in series

When secondary windings (W_{sec}) are connected in series, Irms remains the same, but DCR increases.

Example: For HP6-2400L, connect four secondary windings in series, creating a center tap at pins 9 and 5. For each half of the secondary:

$$\begin{aligned} \text{DCR} &= \text{DCR}_{\text{table}} \times W_{\text{sec}} \\ &= 0.030 \times 2 = 0.060 \text{ Ohms} \end{aligned}$$

$$\begin{aligned} \text{Irms} &= \text{Irms}_{\text{table}} \\ &= 2.9 \text{ A} \end{aligned}$$

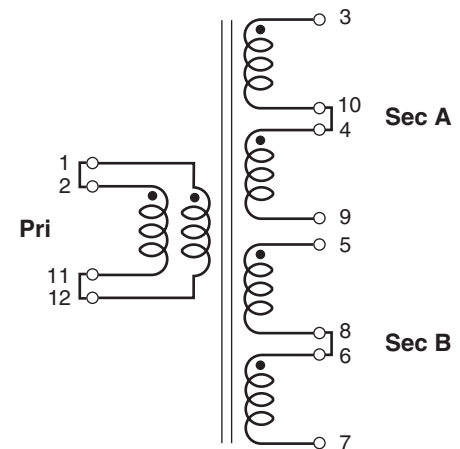

Primary:

$L = 194 \mu\text{H}$
 $\text{DCR} = 0.015 \Omega$
 $\text{Irms} = 5.8 \text{ A}$
 $\text{VT} = 131.9 \text{ V-}\mu\text{sec}$

Each half secondary;

Sec A (3-9), Sec B (5-7):
 $\text{DCR} = 0.06 \Omega$
 $\text{Irms} = 2.9 \text{ A}$



Hexa-Path Magnetics

Formulas used to calculate electrical characteristics

Connecting windings in series

$$\text{Inductance} = \text{Inductance}_{\text{table}} \times (\text{number of windings})^2$$

$$\text{DCR} = \text{DCR}_{\text{table}} \times \text{number of windings}$$

$$\text{Isat} = (\text{Isat}_{\text{table}} \times 6) \div \text{number of windings connected in series}$$

$$\text{Irms} = \text{Irms}_{\text{table}}$$

Connecting windings in parallel

$$\text{Inductance} = \text{Inductance}_{\text{table}}$$

$$\text{DCR} = 1 \div [\text{number of windings} \times (1 \div \text{DCR}_{\text{table}})]$$

$$\text{Isat} = (\text{Isat}_{\text{table}} \times 6) \div \text{number of windings connected in series}$$

$$\text{Irms} = \text{Irms}_{\text{table}} \times \text{number of windings}$$

Create a 1 : 1 gate drive transformer

Choose HP1-1400L

Part number	Inductance (μH)	DCR max (Ohms)	Volt-time product (V-μsec)	Peak energy storage (μJ)	Isat (A)	Irms (A)
HP1-1400L	89.6 ±25%	0.130	23.4	N/A	N/A	0.74

Connecting primary windings in series

When primary windings (W_{pri}) are connected in series, inductance and volt-time product increase, energy storage and Irms remain the same, but DCR increases.

Example: For HPH1-1400L, connect three primary windings in series:

$$\begin{aligned} \text{Inductance} &= \text{Inductance}_{\text{table}} \times W_{\text{pri}}^2 \\ &= 89.6 \times 3^2 = 806.4 \mu\text{H} \end{aligned}$$

$$\begin{aligned} \text{DCR} &= \text{DCR}_{\text{table}} \times W_{\text{pri}} \\ &= 0.130 \times 3 = 0.39 \text{ Ohms} \end{aligned}$$

$$\begin{aligned} \text{VT} &= \text{VT}_{\text{table}} \times W_{\text{pri}} \\ &= 70.2 \text{ V-}\mu\text{sec} \end{aligned}$$

$$\begin{aligned} \text{Irms} &= \text{Irms}_{\text{table}} \\ &= 0.74 \end{aligned}$$

Connecting secondary windings in series

When secondary windings (W_{sec}) are connected in series, Irms remains the same, but DCR increases.

Example: For HP1-1400L, connect three secondary windings in series:

$$\begin{aligned} \text{DCR} &= \text{DCR}_{\text{table}} \times W_{\text{sec}} \\ &= 0.130 \times 3 = 0.39 \text{ Ohms} \end{aligned}$$

$$\begin{aligned} \text{Irms} &= \text{Irms}_{\text{table}} \\ &= 0.74 \end{aligned}$$

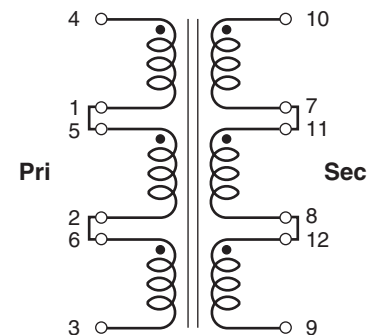

Primary:

$$L = 806.4 \mu\text{H}$$

$$\text{DCR} = 0.39\Omega$$

$$\text{Irms} = 0.74 \text{ A}$$

$$\text{VT} = 70.2 \text{ V-}\mu\text{sec}$$

Secondary:

$$\text{DCR} = 0.39\Omega$$

$$\text{Irms} = 0.74 \text{ A}$$



www.coilcraft.com

US +1-847-639-6400 sales@coilcraft.com
UK +44-1236-730595 sales@coilcraft-europe.com
Taiwan +886-2-2264 3646 sales@coilcraft.com.tw
China +86-21-6218 8074 sales@coilcraft.com.cn
Singapore + 65-6484 8412 sales@coilcraft.com.sg

Document 613-10 Revised 02/12/18

© Coilcraft Inc. 2018

This product may not be used in medical or high risk applications without prior Coilcraft approval. Specification subject to change without notice. Please check web site for latest information.