

NEW!

TLVR Shielded Power Inductors — SLV9080

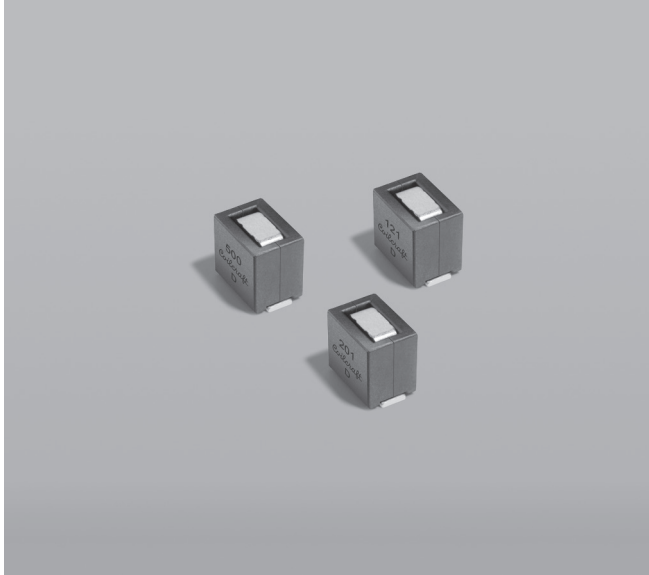

- Trans-inductor Voltage Regulator (TLVR) inductor
- Optimized for fast transient response in multi-phase converter designs
- High efficiency with low DCR
- High saturation current up to 120 A
- AEC-Q200 qualified

Core material Ferrite

Weight 2.1 g

Environmental RoHS compliant, halogen free

Terminations RoHS compliant matte tin over nickel over copper (pins 1 – 4). RoHS compliant tin-silver over copper (pins 2 – 3)

Ambient temperature –40°C to +85°C with (40°C rise) Irms current

Maximum part temperature +125°C (ambient + temp rise). [Derating](#).

Storage temperature Component: –40°C to +125°C.

Tape and reel packaging: –40°C to +80°C

Resistance to soldering heat Max three 40 second reflows at +260°C, parts cooled to room temperature between cycles

Moisture Sensitivity Level (MSL) 1 (unlimited floor life at <30°C / 85% relative humidity)

Packaging 450/13" reel; Plastic tape: 24 mm wide, 0.5 mm thick, 16 mm pocket spacing, 8.55 mm pocket depth

PCB washing Tested to MIL-STD-202 Method 215 plus an additional aqueous wash. See [Doc787_PCB_Washing.pdf](#).

Part number ¹	Inductance ² ±10% (nH)	DCR ³ ±10% (mOhms)		SRF (typ) (MHz)	Isat (A) ⁴			Irms (A) ⁵	
		L1–4	L2–3		at 25°C	at 100°C	at 125°C	20°C rise	40°C rise
SLV9080-500KED	50	0.19	0.33	400	120	101	92	39	54.5
SLV9080-700KED	70	0.19	0.33	210	94	77	71	39	54.5
SLV9080-101KED	100	0.19	0.33	150	73	59	54	39	54.5
SLV9080-121KED	120	0.19	0.33	120	60	49	44	39	54.5
SLV9080-151KED	150	0.19	0.33	100	47	39	35	39	54.5
SLV9080-181KED	180	0.19	0.33	90	41	33	30	39	54.5
SLV9080-201KED	200	0.19	0.33	80	37	31	28	39	54.5

- Packaging:** D = 13" machine-ready reel. EIA-481 embossed plastic tape (450 parts per reel). Quantities less than full reel available: in tape (not machine ready) or with leader and trailer (\$25 charge)
- Inductance at 100 kHz, 0.1 Vrms, 0 Adc.
- DCR is measured on a micro-ohmmeter at points indicated in the diagram below.

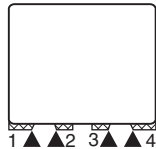

▲ Points used for measuring DCR

- DC current that causes an inductance drop of 20% (typ) from its value without current. [Click for temperature derating information](#).

- Current applied to the primary winding (pins 1–4) that causes the specified temperature rise from a 25°C ambient. This information is for reference only and does not represent absolute maximum ratings. Temperature rise is highly dependent on many factors including pcb land pattern, trace size, air flow, and proximity to other components. Therefore temperature rise should be verified in application conditions. [Click for temperature derating information](#).
- Electrical specifications at 25°C. Refer to Doc 362 "Soldering Surface Mount Components" before soldering.



SLV9080 Shielded Power Inductors

L vs Current vs Temperature

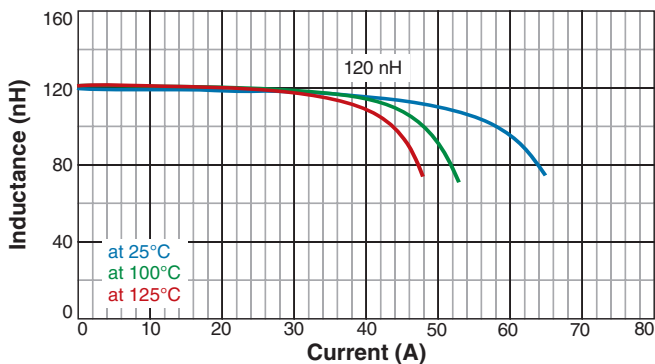
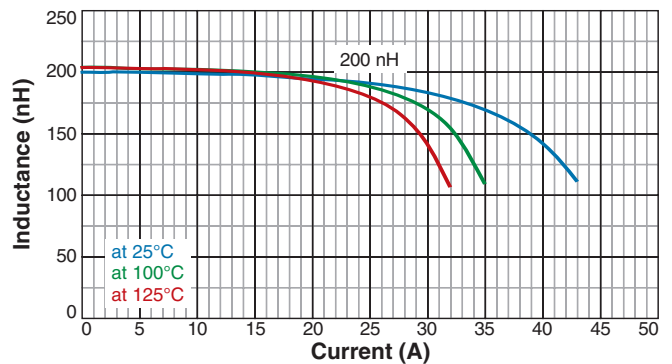
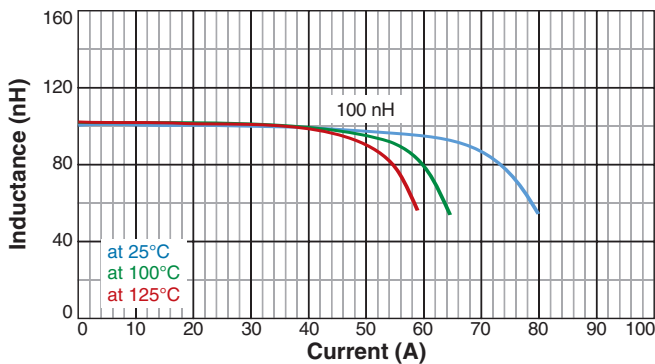
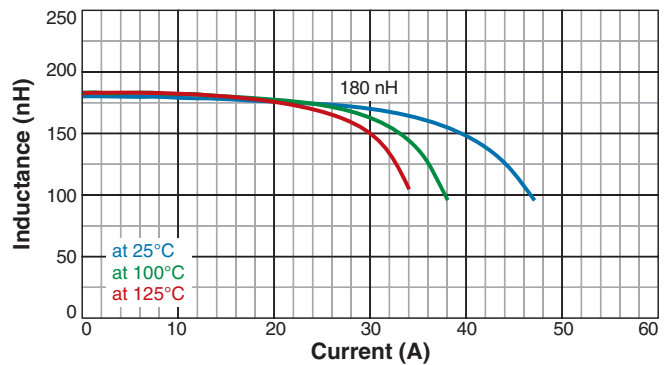
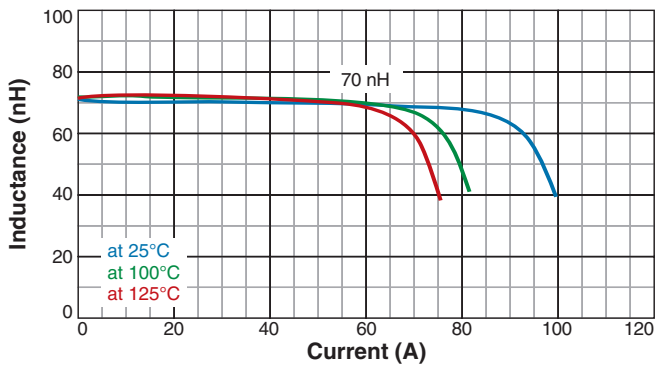
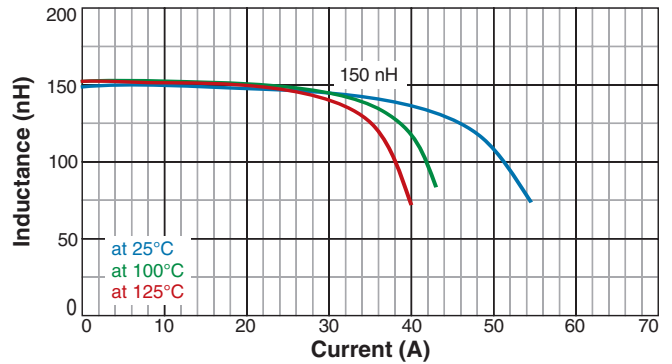
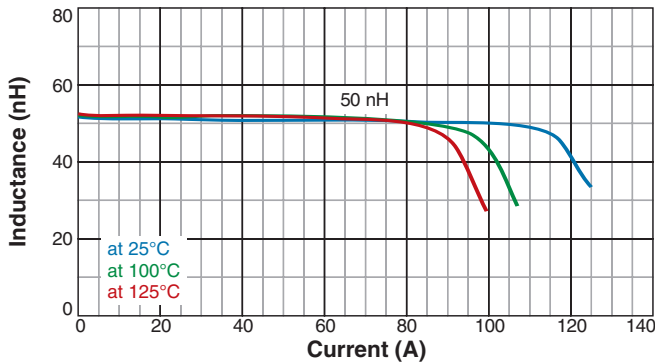

US +1-847-639-6400 sales@coilcraft.com
UK +44-1236-730595 sales@coilcraft-europe.com
Taiwan +886-2-2264 3646 sales@coilcraft.com.tw
China +86-21-6218 8074 sales@coilcraft.com.cn
Singapore + 65-6484 8412 sales@coilcraft.com.sg

Document 1856-2 Revised 03/12/26
 © Coilcraft Inc. 2026
 This product may not be used in medical or high risk applications without prior Coilcraft approval. Specification subject to change without notice. Please check web site for latest information.



SLV9080 Shielded Power Inductors

L vs Frequency

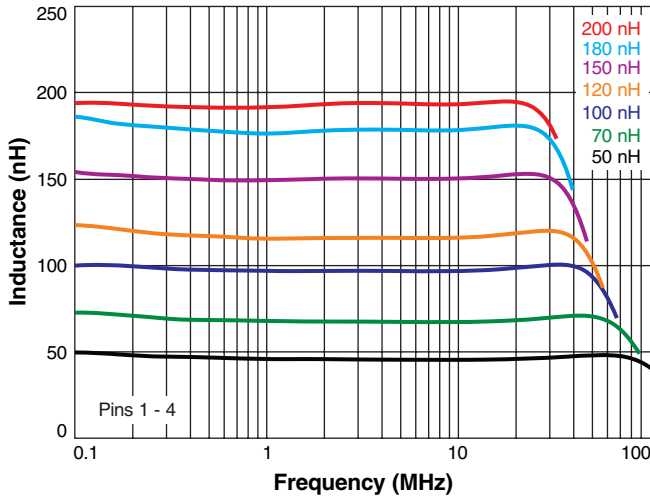

Dimensions

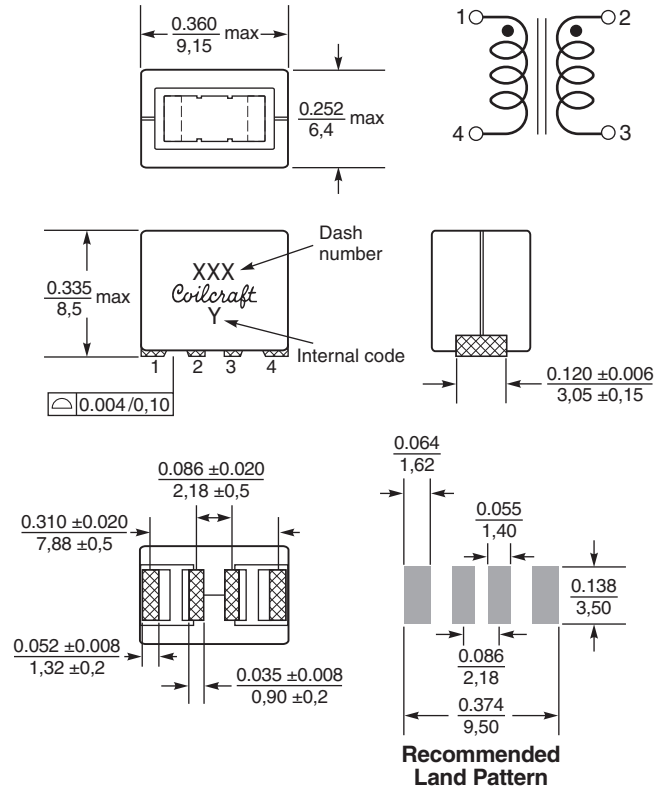

Dimensions are in $\frac{\text{inches}}{\text{mm}}$



US +1-847-639-6400 sales@coilcraft.com
UK +44-1236-730595 sales@coilcraft-europe.com
Taiwan +886-2-2264 3646 sales@coilcraft.com.tw
China +86-21-6218 8074 sales@coilcraft.com.cn
Singapore + 65-6484 8412 sales@coilcraft.com.sg

Document 1856-3 Revised 03/12/26
 © Coilcraft Inc. 2026
 This product may not be used in medical or high risk applications without prior Coilcraft approval. Specification subject to change without notice. Please check web site for latest information.