

# PoC Filter Solution – SMD-POC-004

## Overview

The SMD-POC-004 is for PoC applications spanning a 1 MHz to 4.2 GHz frequency range, injecting a current of 1.2 Amps. The impedance measurement was generated in simulation using measured Z-Parameter files for each component. S-Parameters were generated by taking two SMD-POC-004 boards connected by a Leoni Dacar-302 coaxial cable. Using a DC Power supply, the DC<sub>in</sub> was connected to CON3 of the first board, while the DC<sub>out</sub> was connected to the CON3 of the second board to close the circuit. All measurements were at room temperature and are considered typical responses for the solution.

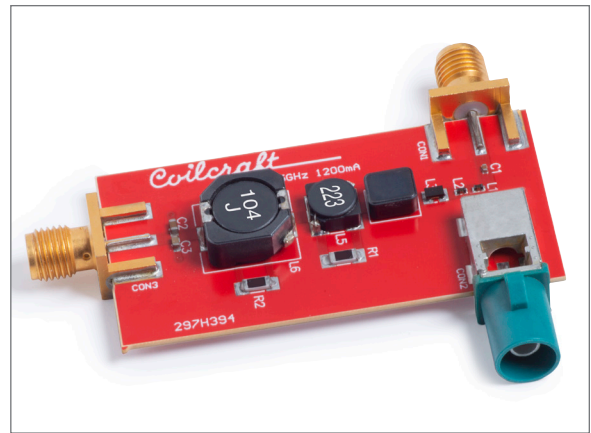

## Coilcraft 1200 mA Solution

Inductors	DCR max. (Ohms)	Max. Area (mm <sup>2</sup> )	Isat (A) 30%		Irms (A)		Notes
			25°C	125°C	25°C	125°C	
0402DF-200 (20nH)	0.049	0.733	—	—	1.40 (15°C rise)	1.20 (15°C rise)	
0402DF-200 (20nH)	0.049	0.733	—	—	1.40 (15°C rise)	1.20 (15°C rise)	
PFL2010-471 (0.47 μH)	0.069	3.190	1.80	0.97	1.90 (40°C rise)	1.10 (15°C rise)	
1812PS-562 (5.6 μH)	0.120	29.230	1.90	1.40	2.10 (40°C rise)	1.79 (40°C rise)	
MSS6132T-223 (22 μH)	0.158	42.250	1.22	1.10	1.90 (40°C rise)	1.61 (40°C rise)	3.0 kΩ resistor in parallel
MSS1048T-104 (100 μH)	0.224	108.150	1.36	1.10	1.48 (40°C rise)	1.20 (40°C rise)	2.0 kΩ resistor in parallel
<b>Totals:</b>	<b>0.669</b>	<b>184.286</b>					

## Schematic

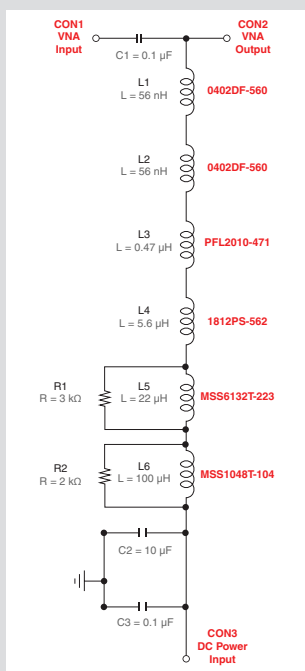

## Impedance vs. Frequency

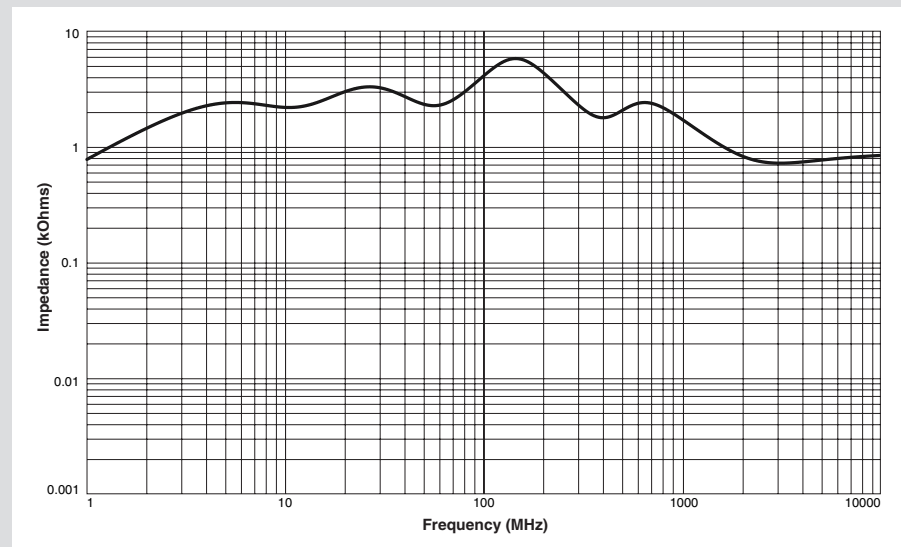

# PoC Filter Solution – SMD-POC-004

**Return Loss (2 m cable)**

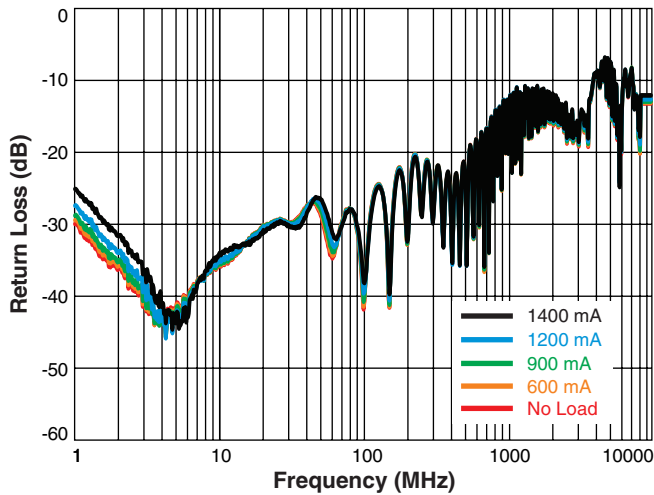

**Return Loss (10 m cable)**

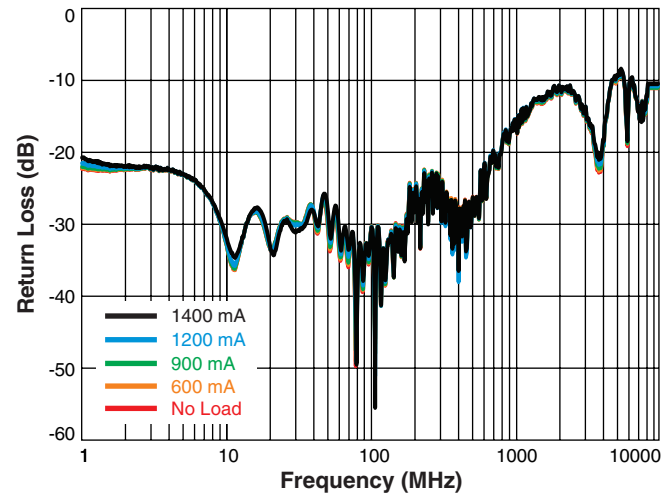

**Insertion Loss (2 m cable)**

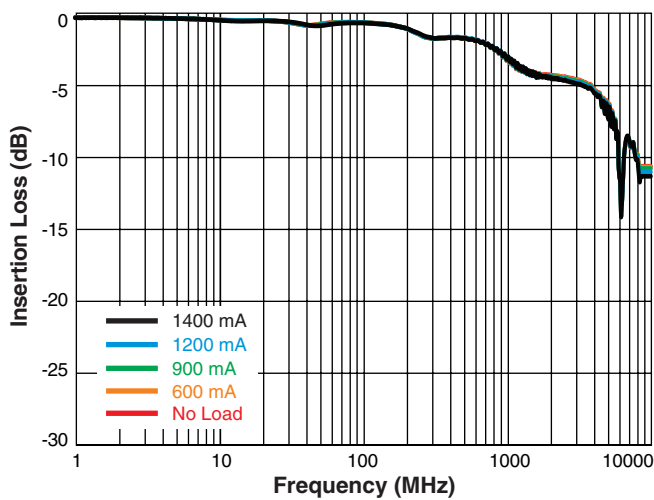

**Insertion Loss (10 m cable)**

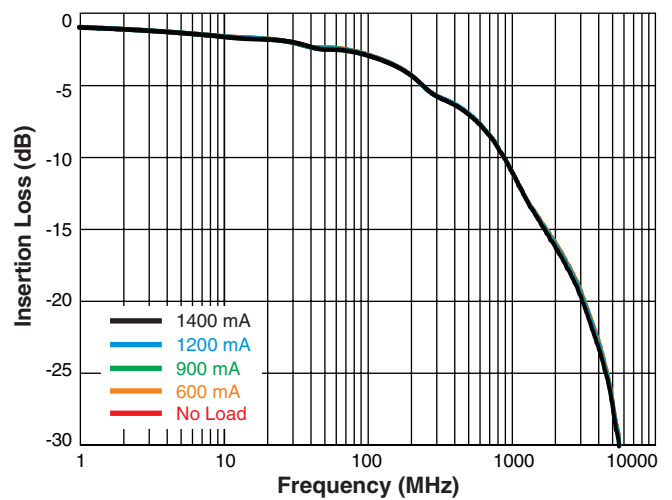

# PoC Filter Solution – SMD-POC-004

## S-Parameters (1200 mA, 2 m cable at temperature)

