

**NEW!**

# Shielded Power Inductors – SLV1211



- Trans-inductor Voltage Regulator (TLVR) inductor
- Optimized for fast transient response in multi-phase converter designs
- High efficiency with low DCR
- High saturation current up to 152 A

**Core material** Ferrite

**Weight** 3.5 – 3.6 g

**Environmental** RoHS compliant, halogen free

**Terminations** RoHS compliant matte tin over nickel over copper.

**Ambient temperature** –40°C to +85°C with (40°C rise) Irms current.

**Maximum part temperature** +125°C (ambient + temp rise). [Derating](#).

**Storage temperature** Component: –40°C to +125°C.

Tape and reel packaging: –40°C to +80°C

**Resistance to soldering heat** Max three 40 second reflows at +260°C, parts cooled to room temperature between cycles

**Moisture Sensitivity Level (MSL)** 1 (unlimited floor life at <30°C / 85% relative humidity)

**Packaging** 450/13" reel; Plastic tape: 24 mm wide, 0.5 mm thick, 12 mm pocket spacing, 11.45 mm pocket depth.

**PCB washing** Tested to MIL-STD-202 Method 215 plus an additional aqueous wash. See [Doc787\\_PCB\\_Washing.pdf](#).

Part number <sup>1</sup>	Inductance <sup>2</sup> ±10% (nH)	DCR <sup>3</sup> ±10% (mOhms)		SRF (typ) (MHz)	Isat (A) <sup>4</sup>			Irms (A) <sup>5</sup>	
		L1–4	L2–3		at 25°C	at 100°C	at 125°C	20°C rise	40°C rise
SLV1211-700KED	70	0.125	0.41	183	152	133	126	43	60
SLV1211-101KED	100	0.125	0.41	138	125	102	97	43	60
SLV1211-121KED	120	0.125	0.41	114	105	87	82	43	60
SLV1211-161KED	160	0.125	0.41	96	77	62	58	43	60
SLV1211-181KED	180	0.125	0.41	79	69	54	51	43	60
SLV1211-201KED	200	0.125	0.41	66	59	47	43	43	60

- Packaging:** D = 13" machine-ready reel. EIA-481 embossed plastic tape (450 parts per reel). Quantities less than full reel available: in tape (not machine ready) or with leader and trailer (\$25 charge).
- Inductance at 100 kHz, 0.1 Vrms, 0 Adc.
- DCR is measured on a micro-ohmmeter at points indicated in the diagram below.

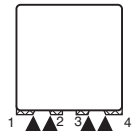

▲ Points used for measuring DCR

- DC current that causes an inductance drop of 20% (typ) from its value without current. [Click for temperature derating information.](#)

- Current applied to the primary winding (pins 1 – 4) that causes the specified temperature rise from a 25°C ambient. This information is for reference only and does not represent absolute maximum ratings. Temperature rise is highly dependent on many factors including pcb land pattern, trace size, air flow, and proximity to other components. Therefore temperature rise should be verified in application conditions. [Click for temperature derating information.](#)
- Electrical specifications at 25°C. Refer to Doc 362 "Soldering Surface Mount Components" before soldering.



# SLV1211 Shielded Power Inductors

## L vs Current vs Temperature

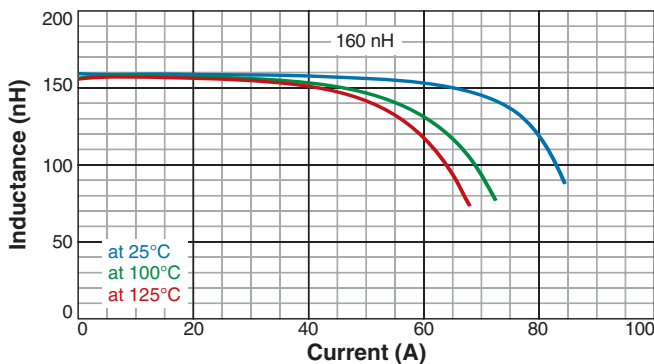
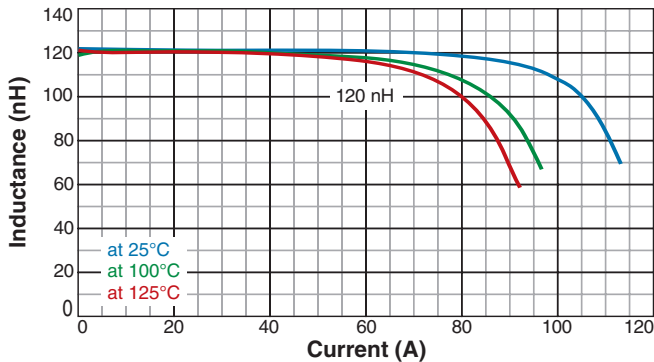
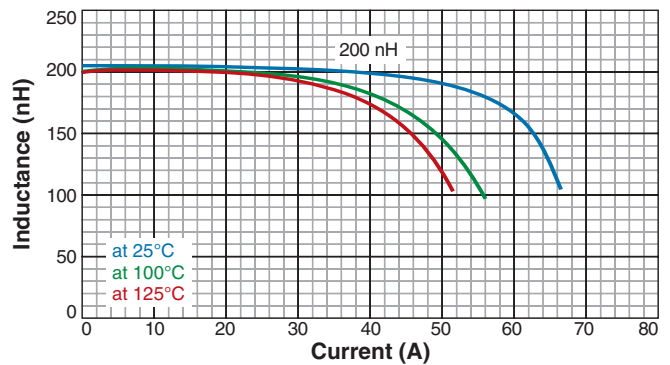
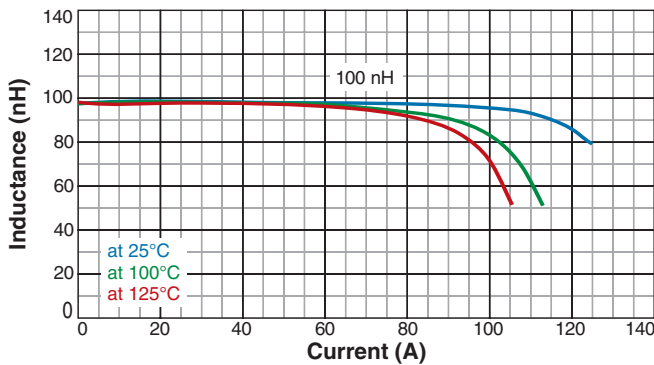
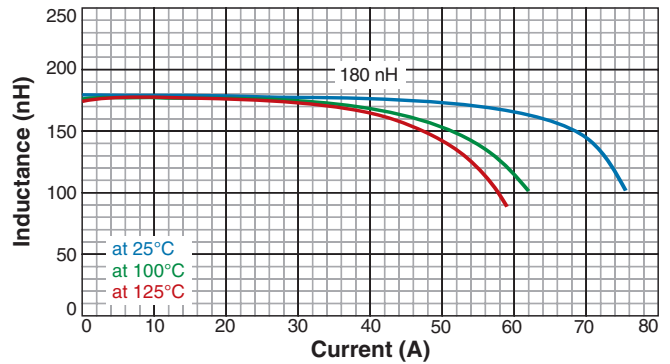
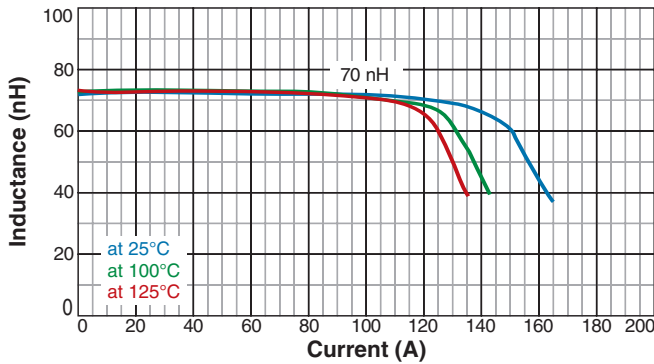

**US** +1-847-639-6400 sales@coilcraft.com  
**UK** +44-1236-730595 sales@coilcraft-europe.com  
**Taiwan** +886-2-2264 3646 sales@coilcraft.com.tw  
**China** +86-21-6218 8074 sales@coilcraft.com.cn  
**Singapore** + 65-6484 8412 sales@coilcraft.com.sg

Document 1827-2 Revised 03/12/26  
 © Coilcraft Inc. 2026  
 This product may not be used in medical or high risk applications without prior Coilcraft approval. Specification subject to change without notice. Please check web site for latest information.



# SLV1211 Shielded Power Inductors

## L vs Frequency

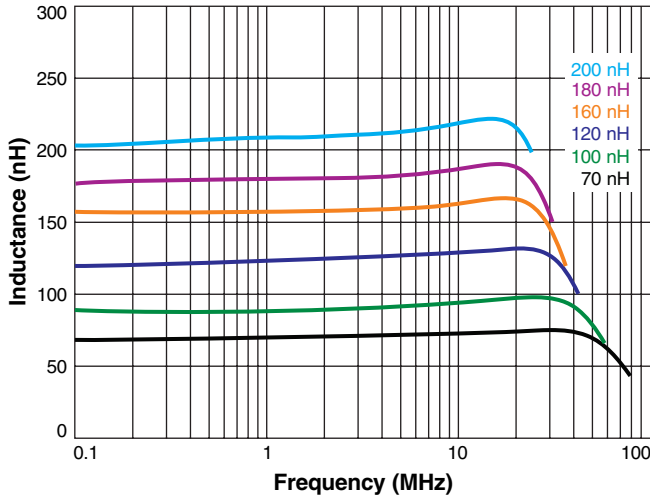

## Dimensions

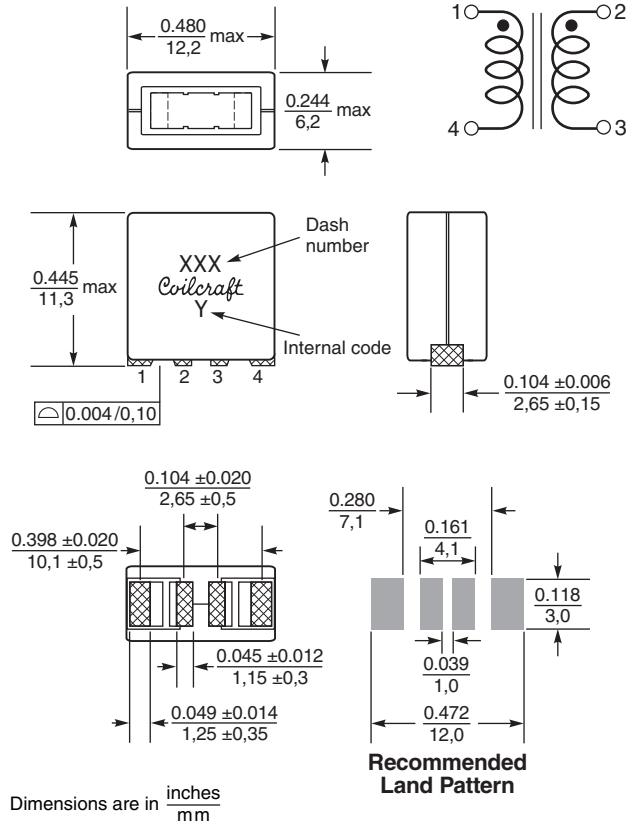

**US** +1-847-639-6400 sales@coilcraft.com  
**UK** +44-1236-730595 sales@coilcraft-europe.com  
**Taiwan** +886-2-2264 3646 sales@coilcraft.com.tw  
**China** +86-21-6218 8074 sales@coilcraft.com.cn  
**Singapore** + 65-6484 8412 sales@coilcraft.com.sg

Document 1827-3 Revised 03/12/26  
 © Coilcraft Inc. 2026  
 This product may not be used in medical or high risk applications without prior Coilcraft approval. Specification subject to change without notice. Please check web site for latest information.