

Shielded Power Inductors – XEL6060



- AEC-Q200 qualified
- Extremely low DCR and ultra low AC losses for high switching frequencies (2 to 5 MHz)
- Superior current handling with soft saturation characteristics
- Can withstand high current spikes

Designer's Kit C466 contains 3 of each value

Core material Composite

Environment RoHS compliant, halogen free

Terminations RoHS compliant tin-silver (96.5/3.5) over copper. Other terminations available at additional cost.

Weight 1.23 – 1.31 g

Operating voltage 80 V⁷

Ambient temperature –40°C to +125°C with (40°C rise) Irms current.

Maximum part temperature +165°C (ambient + temp rise). Derating.

Storage temperature Component: –55°C to +165°C.

Tape and reel packaging: –55°C to +80°C

Resistance to soldering heat Max three 40 second reflows at +260°C, parts cooled to room temperature between cycles

Moisture Sensitivity Level (MSL) 1 (unlimited floor life at <30°C / 85% relative humidity)

Packaging 250/7" reel; 750/13" reel Plastic tape: 16 mm wide, 0.4 mm thick, 8 mm pocket spacing, 6.23 mm pocket depth

PCB washing Tested to MIL-STD-202 Method 215 plus an additional aqueous wash. See [Doc787_PCB_Washing.pdf](#).

Part number ¹	Inductance ² ±20% (µH)	DCR (mOhms) ³		SRF typ ⁴ (MHz)	Isat (A) ⁵			Irms (A) ⁶	
		typ	max		10% drop	20% drop	30% drop	20°C rise	40°C rise
XEL6060-331ME_	0.33	1.98	2.20	79.0	13.0	20.0	30.0	23.6	31.8
XEL6060-561ME_	0.56	2.60	2.90	59.0	11.0	17.0	23.0	20.6	27.7
XEL6060-821ME_	0.82	3.03	3.33	52.0	10.6	16.6	20.0	19.1	25.7
XEL6060-102ME_	1.0	3.70	4.07	47.0	9.8	15.3	20.0	17.2	23.2
XEL6060-152ME_	1.5	4.28	4.71	41.0	9.2	14.2	19.0	16.0	21.6
XEL6060-222ME_	2.2	6.10	6.70	33.0	7.6	11.7	16.0	13.4	18.1
XEL6060-272ME_	2.7	6.94	7.63	26.0	6.5	10.0	13.8	12.6	17.0
XEL6060-472ME_	4.7	13.65	15.02	23.0	5.6	8.5	11.4	9.0	12.1
XEL6060-682ME_	6.8	20.82	22.90	16.0	3.6	5.9	7.9	7.3	9.8
XEL6060-822ME_	8.2	22.71	24.98	15.0	3.5	5.7	7.6	7.0	9.4
XEL6060-123ME_	12	36.66	40.33	12.0	2.7	4.2	5.8	5.5	7.4
XEL6060-333ME_	33	83.2	91.50	7.8	1.9	2.8	3.8	3.0	4.1

1. When ordering, please specify **termination** and **packaging** codes:

XEL6060-333MEC

Termination: E = RoHS compliant tin-silver over copper.

Special order: T = RoHS tin-silver-copper (95.5/4/0.5) or S = non-RoHS tin-lead (63/37).

Packaging: C = 7" machine-ready reel. EIA-481 embossed plastic tape (250 parts per full reel). Quantities less than full reel available: in tape (not machine ready) or with leader and trailer (\$25 charge).

D = 13" machine-ready reel. EIA-481 embossed plastic tape. Factory order only, not stocked (750 parts per full reel).

B = Less than full reel. In an effort to simplify our part numbering system, Coilcraft is eliminating the need for multiple packaging codes. When ordering, simply change the last letter of your part number from B to C.

2. Inductance tested at 1 MHz, 0.1 Vrms, 0 Adc.

3. DCR measured on a micro-ohmmeter.

4. SRF measured using Agilent/HP 4395A or equivalent.

5. DC current at 25°C that causes an inductance drop of 30% (typ) from its value without current.

[Click for temperature derating information.](#)

6. Current that causes the specified temperature rise from 25°C ambient.

This information is for reference only and does not represent absolute maximum ratings. Temperature rise is highly dependent on many factors including pcb land pattern, trace size, air flow, and proximity to other components. Therefore temperature rise should be verified in application conditions. [Click for temperature derating information.](#)

7. Voltage capability varies by part number and in many cases may be higher than the listed voltage.

8. Electrical specifications at 25°C.

Refer to Doc 362 "Soldering Surface Mount Components" before soldering.



www.coilcraft.com

US +1-847-639-6400 sales@coilcraft.com

UK +44-1236-730595 sales@coilcraft-europe.com

Taiwan +886-2-2264 3646 sales@coilcraft.com.tw

China +86-21-6218 8074 sales@coilcraft.com.cn

Singapore + 65-6484 8412 sales@coilcraft.com.sg

Document 1359-1 Revised 06/25/26

© Coilcraft Inc. 2026

This product may not be used in medical or high risk applications without prior Coilcraft approval. Specification subject to change without notice. Please check web site for latest information.

HIGH TEMPERATURE

Shielded Power Inductors – XEL6060

L vs Current

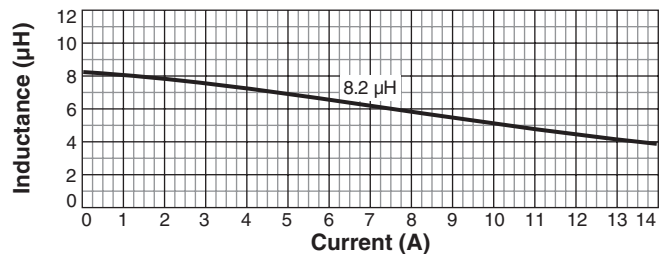
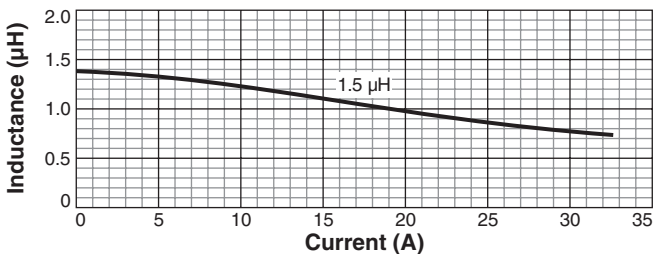
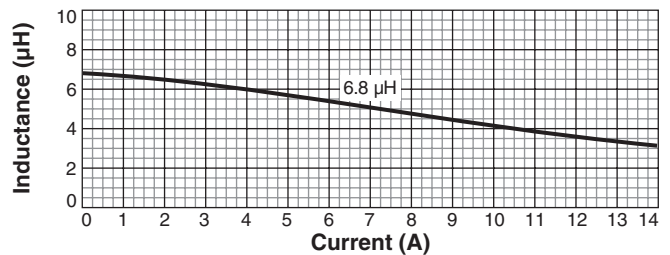
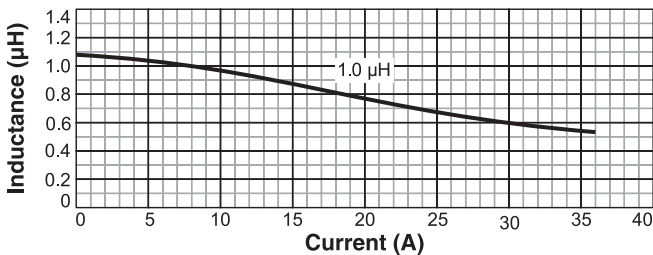
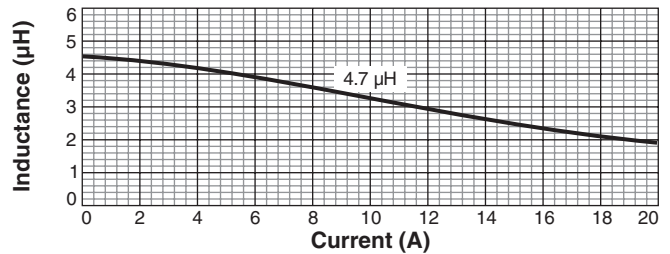
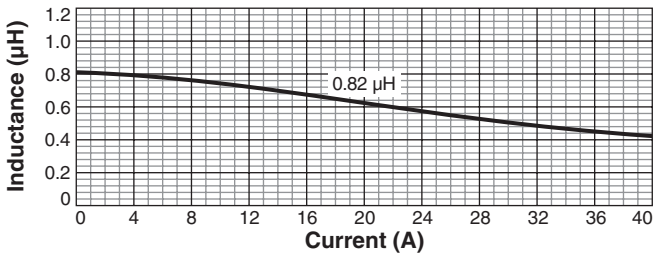
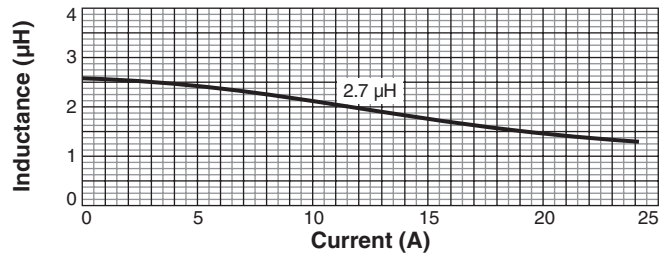
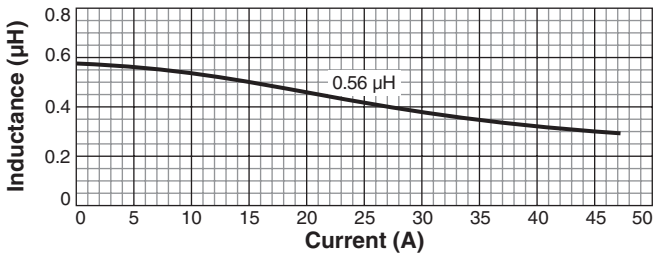
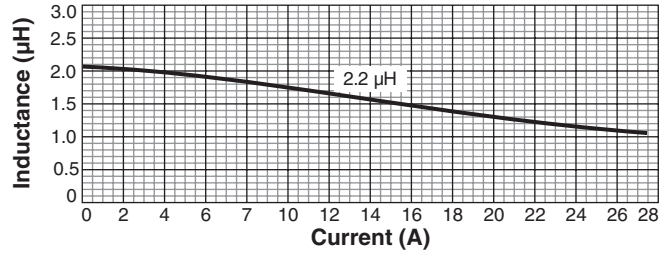
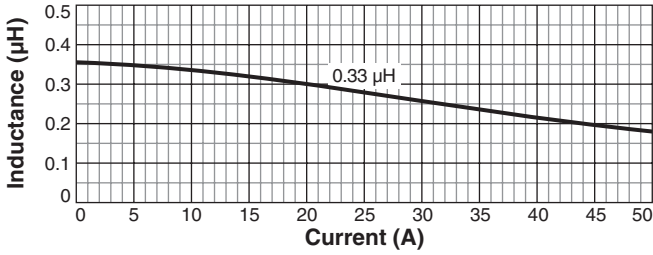

US +1-847-639-6400 sales@coilcraft.com
UK +44-1236-730595 sales@coilcraft-europe.com
Taiwan +886-2-2264 3646 sales@coilcraft.com.tw
China +86-21-6218 8074 sales@coilcraft.com.cn
Singapore + 65-6484 8412 sales@coilcraft.com.sg

Document 1359-2 Revised 06/25/26
 © Coilcraft Inc. 2026
 This product may not be used in medical or high risk applications without prior Coilcraft approval. Specification subject to change without notice. Please check web site for latest information.

HIGH TEMPERATURE

Shielded Power Inductors – XEL6060



L vs Current

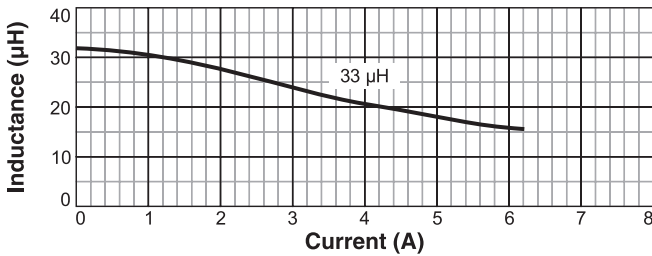
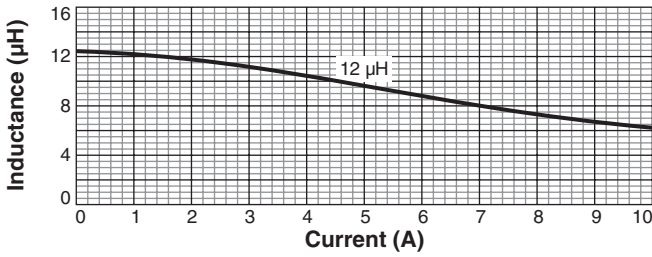

L vs Frequency

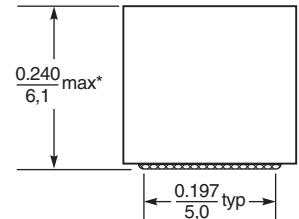
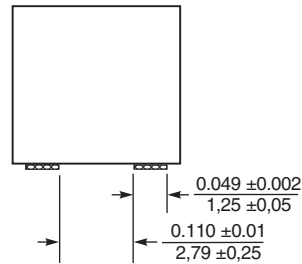
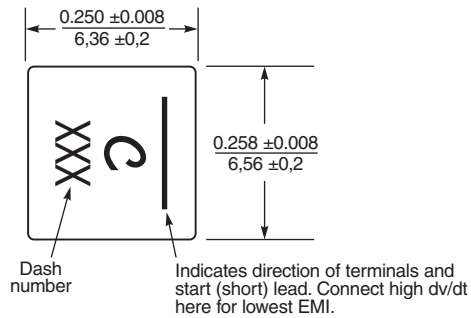
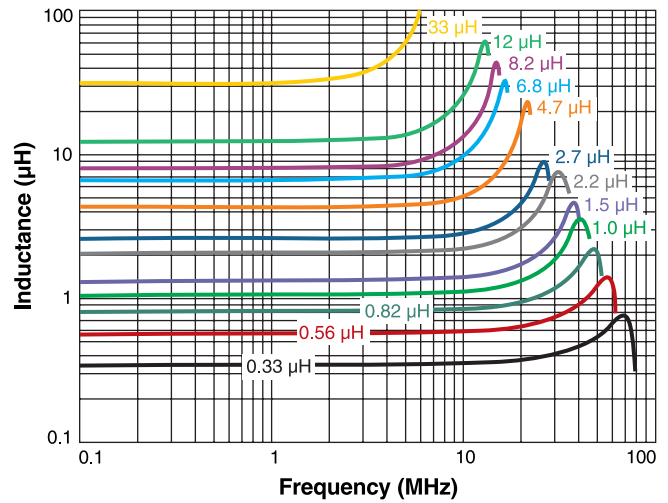

* For optional tin-lead and tin-silver-copper terminations, dimensions are for the mounted part. Dimensions before mounting can be an additional 0.005 inch / 0.13 mm.

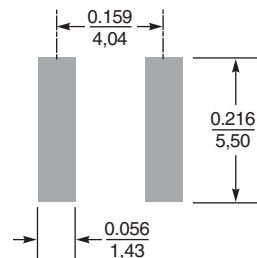

Recommended Land Pattern

Dimensions are in inches/mm



US +1-847-639-6400 sales@coilcraft.com
UK +44-1236-730595 sales@coilcraft-europe.com
Taiwan +886-2-2264 3646 sales@coilcraft.com.tw
China +86-21-6218 8074 sales@coilcraft.com.cn
Singapore + 65-6484 8412 sales@coilcraft.com.sg

Document 1359-3 Revised 06/25/26
 © Coilcraft Inc. 2026
 This product may not be used in medical or high risk applications without prior Coilcraft approval. Specification subject to change without notice. Please check web site for latest information.