

# Build Your LC Filter with Coilcraft Reference Designs



## LC Filter Reference Design uses off-the-shelf components

LC filters are widely used in many applications to provide a variety of frequency characteristics. While passive filters may seem simpler in concept than active filters, design and performance verification can still be a time consuming process, involving some trial and error. To simplify LC filter design, especially high order filters that require more complex computations, Coilcraft has created LC filter reference designs, including 3rd order Butterworth low-pass and high-pass, as well as 7th order elliptic. These designs demonstrate the high performance that can be achieved using Coilcraft inductors and standard capacitors.

LC Filters are classified as low-pass, high-pass, band-pass, and band-stop. They can be identified by their particular frequency response characteristics, including Butterworth, Chebyshev, Bessel, and Elliptic. Each has certain advantages and disadvantages and represents various trade-offs between the pass-band ripple and stop-band attenuation.

### Benefits of Coilcraft Reference Designs

Free filter design programs are available that provide ideal element component values that can be used when starting an LC filter design. One such program, *Design LC filter*, is available at <http://www.wa4dsy.net/filter/filterdesign.html>. For example, to achieve a 3rd order low-pass LC filter providing the cutoff frequency at 1200 MHz, the program suggests the ideal model with component values L1, L2 = 6.6 nH and C1 = 5.31 pF (see Figure 1). These values can be used as a starting point for the real filter design. However, without considering component and PCB parasitics, they may not be very close to real-world perfor-

mance, resulting in a time consuming process of tuning and adjusting, particularly for the high cutoff frequency filters.

For a high performance design example including component parasitic effects and PCB board parasitic interactions of the components with the circuit board, Coilcraft offers 3rd order Butterworth low-pass filter reference designs. The Butterworth low-pass filter uses two 3.9 nH 0805HT Series inductors and a 3.6 pF capacitor targeting a 1200 MHz cutoff frequency. The frequency response of the filter measured with the LC components mounted on a 25 mil thick ceramic substrate yields a cutoff frequency of approximately 1100 MHz. The difference between the calculated value and the real measurement reflects the component parasitic effects and the circuit board effects.

On the other hand, simulating the design including the inductor parasitics by using s-parameters predicts a cutoff frequency of 1700 MHz (Figure 2), which is not particularly close. This suggests the non-ideal PCB characteristics and parasitic arising from the connection of the components to the PCB are significant and must be included to make the model complete. In any event, the reference design measurements provide a handy, accurate, real-world picture of filter performance

### Third Order Butterworth Reference Design (page 4)

The 3rd order Butterworth LC low-pass and high-pass filters are two common types. The frequency response of the Butterworth filter has the least pass-band ripple.

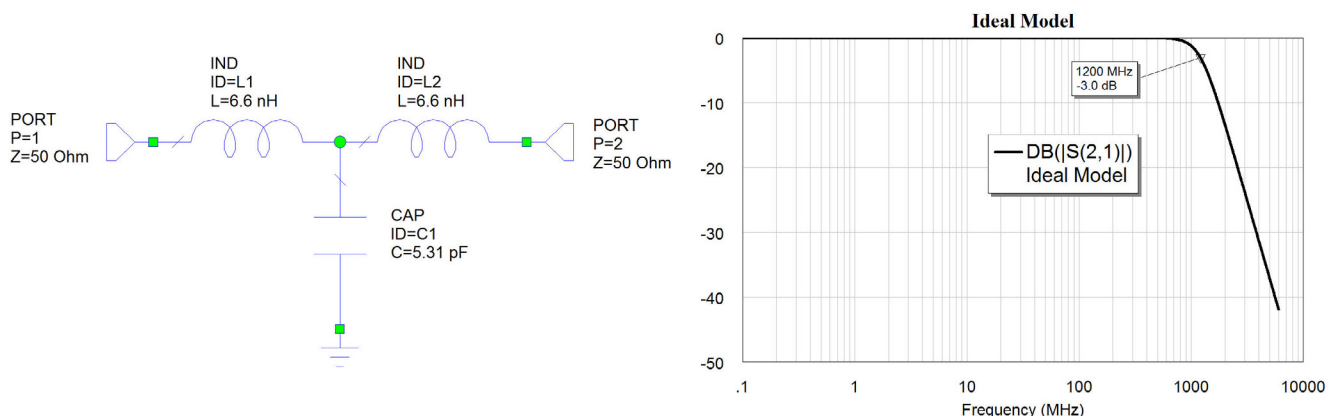

Figure 1.

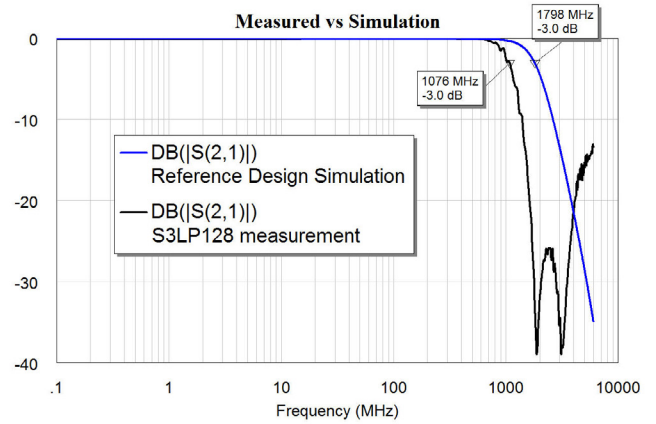
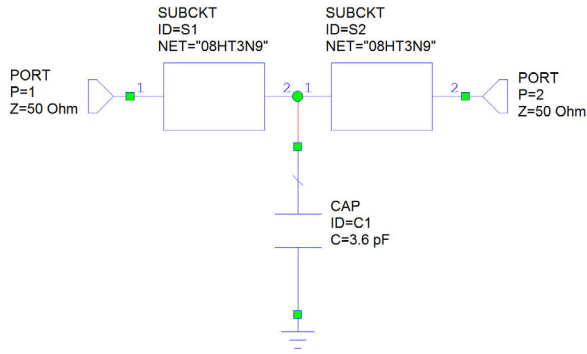

Figure 2.

The inductors selected for 3rd order Butterworth reference designs are off-the-shelf Coilcraft 0805HT series. These wirewound ceramic chip inductors are low profile (only 0.035 inch high) and have a small footprint, offering tremendous board space saving. The 0805HT has tight tolerance at 2% to ensure that the required performance is obtained. The designs feature 50 Ohm characteristic impedance and less than 0.3 dB insertion loss.

The 3rd order low-pass filters reference design provides a wide range of cut-off frequencies from 3 MHz to 3 GHz.

For 3-pole high-pass filter, 15 MHz to 900 MHz cutoff frequencies could be obtained. User may simply order the part number in the reference design BOM list to get the closest component values for the design requirements.

The designer may modify or enhance the filter design based on Coilcraft reference design (e.g., by using larger inductors to achieve improved performance). Coilcraft offers a wide range of off-the-shelf inductors that designers can choose from.

### Frequency Response – 3 Pole Low-Pass Filters\*

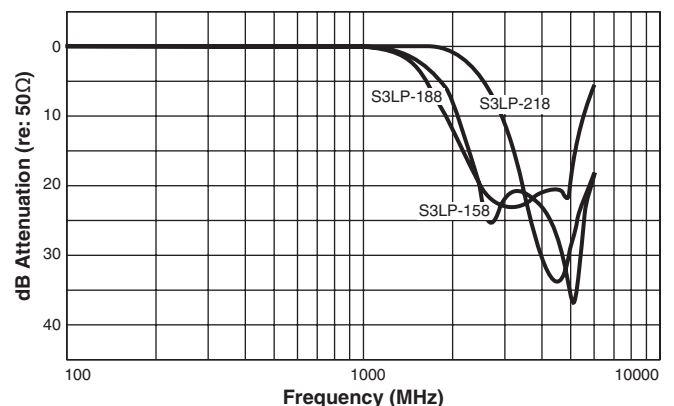
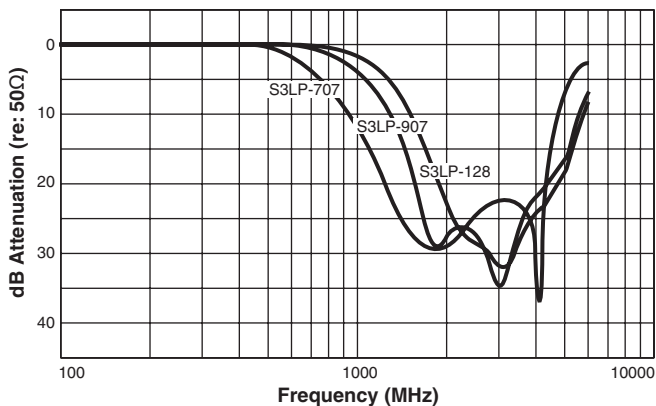
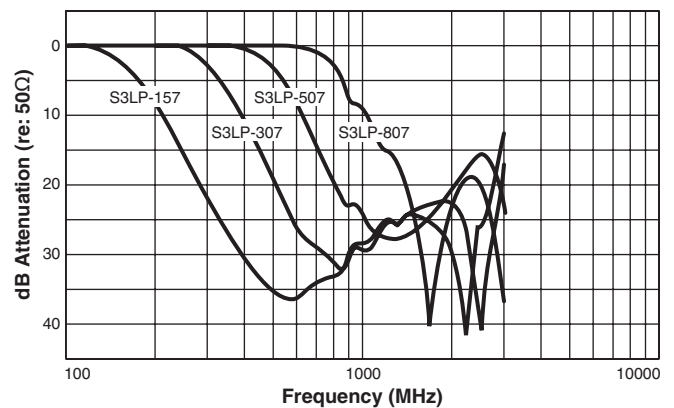
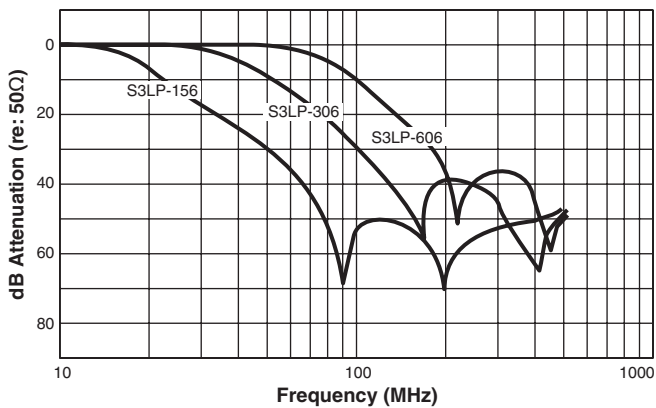

\*Measured on Agilent/HP 8753D network analyzer (re: 50Ω)

## Frequency Response – 3 Pole High Pass Filters\*

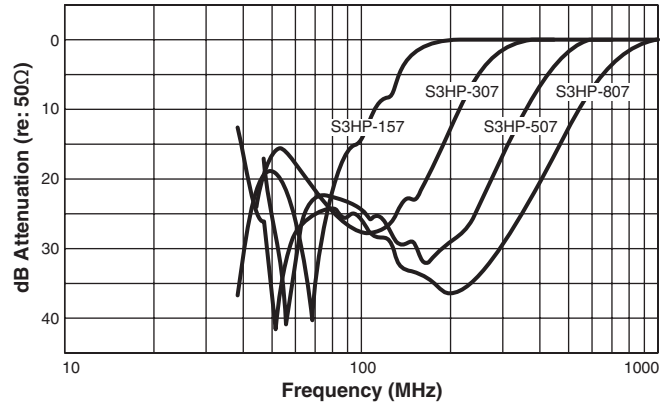
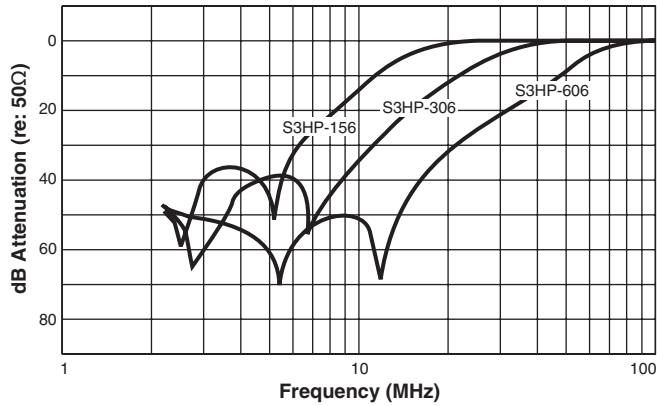

## Seventh Order Elliptic Filter Reference Design (page 5)

Compared to a Butterworth filter, elliptic filters have equalized ripple in both the passband and the stop-band. However, for the same order level, it has the fastest transition between passband and the stop-band. Coilcraft offers 7th order elliptic reference designs with less than 0.3 dB insertion loss and 50-Ohm characteristic impedance. The off-the-shelf selection of inductors is our 1812LS Series ferrite chip inductor. The tolerance is as low as 5%. These seventh order elliptic lowpass filters offer sharp roll-off rate at 80 dB/dec and wide range of cutoff frequencies from 0.3 MHz to 500 MHz.

## Summary

Typically, a passive LC filter design starts with calculations and then a very iterative trial-and-error process.

Coilcraft LC filter reference designs can save time, effort and cost for LC passive filter designers, allowing them to better select the right components and achieve desired performance. The reference designs included in this app note include BOMs of standard off-the-shelf inductors and capacitor values. For further discussion of the LC filter design program and inductor models, refer to the application note "[Passive LC Filter Design and Analysis](#)".

## Frequency Response – 7 Pole Filters\*

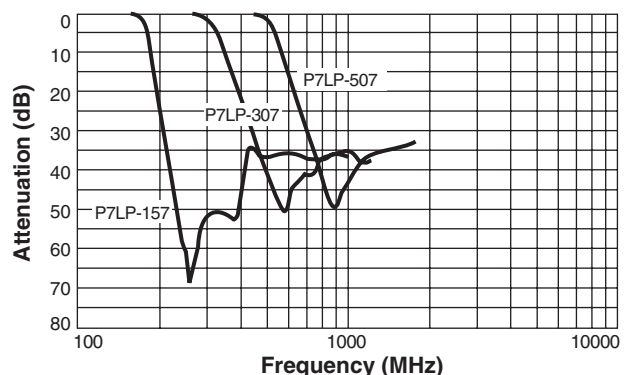
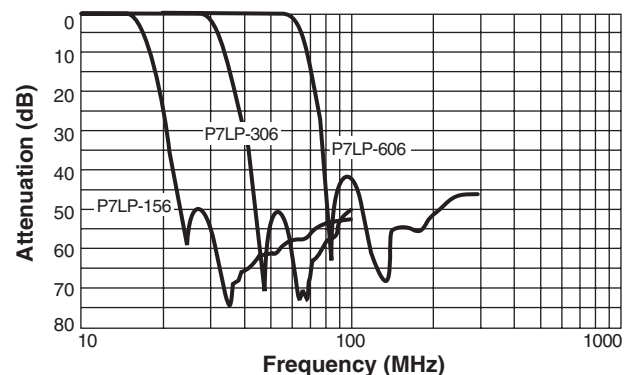
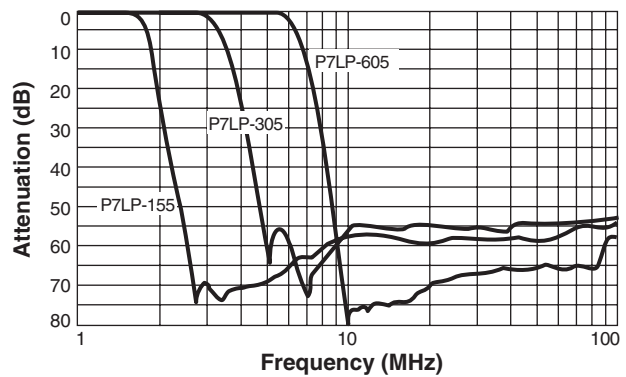
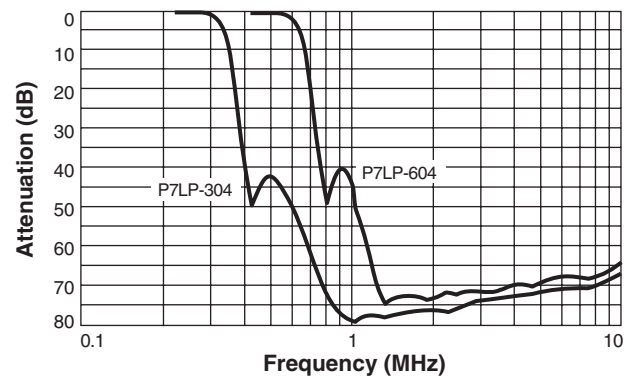

\*Measured on Agilent/HP 8753D network analyzer (re: 50Ω)

# LC Filter Circuit Designs

## Designing low- and high-pass filters using off-the shelf components

These low and high pass filter circuits serve a wide variety of filtering requirements. The design features 3rd order Butterworth alignment, 50 Ohm characteristic impedance and low insertion loss.

The S3LP and S3HP reference designs can incorporate the components into an overall 1812 size surface mount package.

### 3-Pole Low Pass Filters

Coilcraft design number	-3 dB cutoff (MHz)	L1 part number	L2 part number	L1 (nH)	L2 (nH)	C1 ±2% (pF)
S3LP305L	3	0805HT-R79TGFB	0805HT-R79TGFB	790 ±2%	790 ±2%	2400
S3LP605L	6	0805HT-R79TGFB	0805HT-R79TGFB	790 ±2%	790 ±2%	1200
S3LP106L	10	0805HT-R63TGFB	0805HT-R63TGFB	630 ±2%	630 ±2%	680
S3LP136L	13	0805HT-R63TGFB	0805HT-R63TGFB	630 ±2%	630 ±2%	470
S3LP156L	15	0805HT-R50TGFB	0805HT-R50TGFB	500 ±2%	500 ±2%	390
S3LP306L	30	0805HT-R18TGFB	0805HT-R18TGFB	180 ±2%	180 ±2%	220
S3LP456L	45	0805HT-R18TGFB	0805HT-R18TGFB	180 ±2%	180 ±2%	120
S3LP606L	60	0805HT-R12TGFB	0805HT-R12TGFB	120 ±2%	120 ±2%	100
S3LP706L	70	0805HT-R10TGFB	0805HT-R10TGFB	100 ±2%	100 ±2%	91
S3LP956L	95	0805HT-72NTGLB	0805HT-72NTGLB	72 ±2%	72 ±2%	62
S3LP107L	100	0805HT-68NTGLB	0805HT-68NTGLB	68 ±2%	68 ±2%	56
S3LP117L	110	0805HT-68NTGLB	0805HT-68NTGLB	68 ±2%	68 ±2%	56
S3LP157L	150	0805HT-68NTGLB	0805HT-68NTGLB	68 ±2%	68 ±2%	33
S3LP207L	200	0805HT-33NTGLB	0805HT-33NTGLB	33 ±2%	33 ±2%	30
S3LP237L	230	0805HT-33NTGLB	0805HT-33NTGLB	33 ±2%	33 ±2%	24
S3LP307L	300	0805HT-33NTGLB	0805HT-33NTGLB	33 ±2%	33 ±2%	15
S3LP357L	350	0805HT-18NTGLB	0805HT-18NTGLB	18 ±2%	18 ±2%	15
S3LP407L	400	0805HT-17NTGLB	0805HT-17NTGLB	17 ±2%	17 ±2%	12
S3LP457L	450	0805HT-18NTGLB	0805HT-18NTGLB	18 ±2%	18 ±2%	10
S3LP507L	500	0805HT-18NTGLB	0805HT-18NTGLB	18 ±2%	18 ±2%	9.1
S3LP707L	700	0805HT-8N2TJLB	0805HT-8N2TJLB	8.2 ±5%	8.2 ±5%	6.8
S3LP807L	800	0805HT-8N2TJLB	0805HT-8N2TJLB	8.2 ±5%	8.2 ±5%	5.6
S3LP907L	900	0805HT-4N7TJLB	0805HT-4N7TJLB	4.7 ±5%	4.7 ±5%	5.6
S3LP108L	1000	0805HT-3N9TJLB	0805HT-3N9TJLB	3.9 ±5%	3.9 ±5%	4.7
S3LP128L	1200	0805HT-3N9TJLB	0805HT-3N9TJLB	3.9 ±5%	3.9 ±5%	3.6
S3LP158L	1500	0805HT-3N9TJLB	0805HT-3N9TJLB	3.9 ±5%	3.9 ±5%	2.7
S3LP168L	1600	0805HT-2N2TJLB	0805HT-2N2TJLB	2.2 ±5%	1.8 ±5%	2.7
S3LP188L	1800	0805HT-1N8TJLB	0805HT-1N8TJLB	1.8 ±5%	1.8 ±5%	2.0
S3LP218L	2000	0805HT-1N8TJLB	0805HT-1N8TJLB	1.8 ±5%	1.8 ±5%	1.5
S3LP268L	2600	0805HT-1N8TJLB	0805HT-1N8TJLB	1.8 ±5%	1.8 ±5%	1.0
S3LP308L	3000	0805HT-1N8TJLB	0805HT-1N8TJLB	1.8 ±5%	1.8 ±5%	0.5

### 3-Pole High Pass Filters

Coilcraft design number	-3 dB cutoff (MHz)	L1 part number	L1 (nH)	C1 ±2% (pF)	C2 ±2% (pF)
S3HP156L	15	0805HT-R22TGLB	220 ±2%	330	390
S3HP306L	30	0805HT-R18TGLB	180 ±2%	68	68
S3HP606L	60	0805HT-68NTGLB	68 ±2%	56	56
S3HP107L	100	0805HT-39NTGLB	39 ±2%	39	39
S3HP157L	150	0805HT-27NTGLB	27 ±2%	20	20
S3HP307L	300	0805HT-15NTGLB	15 ±2%	6.8	6.8
S3HP507L	500	0805HT-6N8TJLB	6.8 ±5%	5.6	5.6
S3HP707L	700	0805HT-3N9TJLB	3.9 ±5%	4.5	4.5
S3HP807L	800	0805HT-3N9TJLB	3.9 ±5%	3.0	3.0
S3HP907L	900	0805HT-3N9TJLB	3.9 ±5%	2.2	2.2

#### Notes:

All values are for reference only. Layout and substrate affect final performance.  
 3rd order Butterworth filter (refer to schematics). Ref. 50 Ohms.  
 Improved performance may be achieved by using other (typically larger) inductors.  
 Use the [RF Inductor Finder](#) tool to find alternatives.

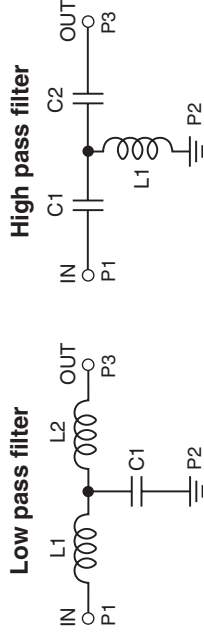

# LC Filter Circuit Designs



## Designing low- and high-pass filters using off-the shelf components

These low-pass filter circuits serve a wide variety of filtering requirements. The design features 7th order elliptic alignment, 50 Ohm characteristic impedance and low insertion loss.

The P7LP reference designs incorporate the components shown in the table below.

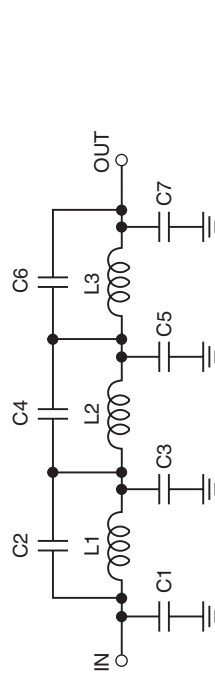

## 7-Pole Low Pass Filters

Coilcraft design number	-3 dB cutoff (MHz)	L1 part number	L2 part number	L3 part number	L1 ±5% (nH)	L2 ±5% (nH)	L3 ±5% (nH)	C1 ±5% (pF)	C2 ±5% (pF)	C3 ±5% (pF)	C4 ±5% (pF)	C5 ±5% (pF)	C6 ±5% (pF)	C7 ±5% (pF)
P7LP-304L	0.30	1812LS-333XJLB	1812LS-333XJLB	1812LS-273XJLB	33000	33000	27000	6800	510	15000	3300	15000	1500	5600
P7LP-604L	0.50	1812LS-183XJLB	1812LS-223XJLB	1812LS-183XJLB	18000	22000	18000	3300	270	6800	1800	6800	910	2200
P7LP-604L	0.60	1812LS-183XJLB	1812LS-183XJLB	1812LS-153XJLB	18000	18000	15000	3300	270	6800	1800	6800	910	2200
P7LP-624L	0.62	1008LS-153XJLB	1008LS-153XJLB	1008LS-153XJLB	15000	15000	15000	3300	240	6800	1000	6800	910	2200
P7LP-804L	0.80	1812LS-123XJLB	1812LS-123XJLB	1812LS-153XJLB	12000	12000	15000	2200	150	5600	750	5600	560	1800
P7LP-904L	0.90	1812LS-123XJLB	1812LS-123XJLB	1812LS-103XJLB	12000	12000	10000	2200	200	5600	820	5600	680	1800
P7LP-105L	1.0	1812CS-103XJLB	1812CS-103XJLB	1812CS-822XJLB	10000	10000	8200	1800	160	4700	680	4700	560	1500
P7LP-135L	1.3	1008CS-472XJLB	1008CS-472XJLB	1008CS-472XJLB	4700	4700	4700	1500	110	1800	620	1800	1800	1500
P7LP-155L	1.5	1008LS-682XJLB	1008LS-682XJLB	1008LS-562XJLB	6800	6800	5600	1200	100	3300	510	3300	360	1000
P7LP-205L	2.0	1008LS-332XJLB	1008LS-332XJLB	1008LS-332XJLB	3300	3300	3300	1200	100	3300	510	3300	360	1000
P7LP-305L	3.0	1008LS-332XJLB	1008LS-332XJLB	1008LS-272XJLB	3300	3300	2700	620	50	1500	300	1500	180	510
P7LP-425L	4.2	1008CS-182XJLB	1008CS-182XJLB	1008CS-182XJLB	1800	1800	1800	620	50	1200	300	1200	180	50
P7LP-455L	4.5	1008CS-152XJLB	1008CS-621XJLB	1008CS-821XJLB	1500	620	820	600	210	710	1200	560	800	250
P7LP-505L	5.0	1008CS-182XJLB	1008CS-222XJLB	1008CS-182XJLB	1800	2200	1800	390	30	910	130	910	110	300
P7LP-605L	6.0	1008CS-222XJLB	1008CS-272XJLB	1008CS-222XJLB	2200	2700	2200	240	200	620	90	560	75	220
P7LP-905L	9.0	1008CS-102XJLB	1008CS-102XJLB	1008CS-102XJLB	1000	1000	1000	220	3000	560	120	560	100	200
P7LP-106L	10	1008CS-102XJLB	1008CS-102XJLB	1008CS-102XJLB	1000	1000	1000	200	16	510	100	510	600	160
P7LP-156L	15	1008CS-681XJLB	1008CS-681XJLB	1008CS-561XJLB	680	680	560	130	10	330	75	300	36	100
P7LP-176L	17	1008CS-911XJLB	1008CS-911XJLB	1008CS-911XJLB	910	910	910	120	6	180	27	180	27	120
P7LP-206L	20	1008CS-561XJLB	1008CS-561XJLB	1008CS-471XJLB	560	560	470	100	10	270	39	270	3000	100
P7LP-306L	30	1008CS-331XJLB	1008CS-221XJLB	1008CS-221XJLB	330	220	220	100	15	140	75	120	56	70
P7LP-456L	45	1008CS-221XJLB	1008CS-181XJLB	1008CS-181XJLB	220	180	180	47	8.2	68	47	56	3000	3000
P7LP-606L	60	1008CS-151XJLB	1008CS-151XJLB	1008CS-121XJLB	150	150	120	30	2.7	68	24	600	9.1	27
P7LP-706L	70	1008CS-151XJLB	1008CS-151XJLB	1008LS-121XJLB	150	150	120	27	2.2	600	1000	600	7.5	200
P7LP-886L	88	1008CS-121XJLB	1008CS-121XJLB	1008CS-121XJLB	120	120	120	20	1.6	50	10	47	6.2	18
P7LP-906L	90	1008CS-121XJLB	1008CS-121XJLB	1008LS-101XJLB	120	120	100	20	1.6	50	10	47	6.2	18
P7LP-107L	100	1008CS-101XJLB	1008CS-101XJLB	1008CS-850XJLB	100	100	85	20	1.8	47	7.5	47	6	16
P7LP-157L	150	1008CS-620XJLB	1008CS-680XJLB	1008CS-500XJLB	62	68	50	100	1	30	4.7	30	3.3	10
P7LP-207L	200	1008CS-470XJLB	1008CS-470XJLB	1008CS-390XJLB	47	47	39	8.2	1	200	3	200	2.2	6.8
P7LP-227L	220	1008CS-330XJLB	1008CS-330XJLB	1008CS-330XJLB	33	33	33	8.2	1	200	3	200	2.2	6.8
P7LP-257L	250	1008CS-150XJLB	1008CS-120XJLB	1008CS-270XJLB	15	12	27	1.2	10	8.2	17	10	2.7	6
P7LP-307L	300	1008CS-270XJLB	1008CS-180XJLB	1008CS-180XJLB	27	18	18	8.2	1.5	10	7	9.5	5.1	5.6
P7LP-407L	400	1008CS-180XJLB	1008CS-120XJLB	1008CS-120XJLB	18	12	12	6.5	1	9.1	5.1	8.2	3.9	4.7
P7LP-507L	500	1008CS-100XJLB	0805CS-060XJLB	0805CS-060XJLB	10	6.8	6.8	4.7	1	5.6	6.2	4.3	4.3	3

### Notes:

All values are for reference only. Layout and substrate affect final performance.

7th order elliptic filter (refer to schematics), Ref. 50 Ohms.

Use 0805 NPO/COG capacitors. Higher cut-off frequencies may require tighter tolerance.

Improved performance may be achieved by using other (typically larger) inductors. Use the [RF Inductor Finder](#) tool to find alternatives.