



Shielded Power Inductors – DS1608C



These shielded inductors can help achieve significantly longer battery life in handheld devices and other portable products.

They offer high efficiency and small size. Their flat top and heat resistant materials ensure trouble-free assembly and reflow operations.

Coilcraft will continue to manufacture and support the DS1608C indefinitely. For new designs, consider the MSS7341, MSS1038 or LPS4018 as alternatives. These series are more cost effective and offer better current handling. In addition, the LPS4018 is a significantly smaller part.

SPICE models ON OUR WEB SITE

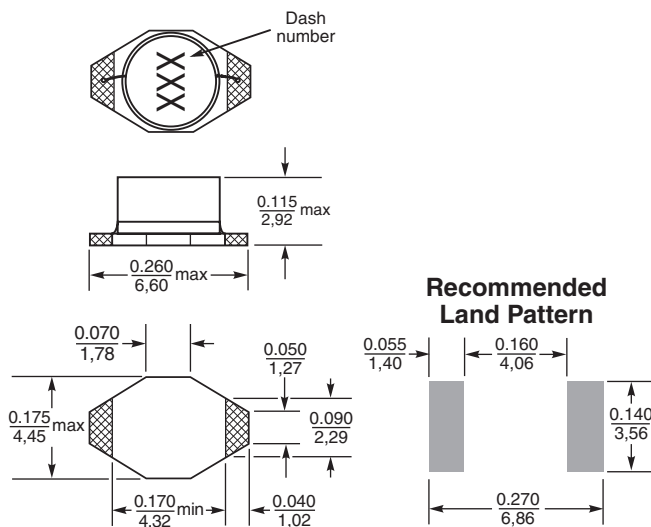

Core material Ferrite

Terminations RoHS compliant electroplated gold (<50 µin) over nickel over moly-manganese. Other terminations available at additional cost.

Weight 144–167 mg

Ambient temperature –40°C to +85°C with Isat current

Maximum part temperature +105°C (ambient + temp rise)

Storage temperature Component: –40°C to +105°C.

Tape and reel packaging: –40°C to +80°C

Resistance to soldering heat Max three 40 second reflows at +260°C, parts cooled to room temperature between cycles

Moisture Sensitivity Level (MSL) 1 (unlimited floor life at <30°C / 85% relative humidity)

Packaging 750/7" reel; 2500/13" reel Plastic tape: 12 mm wide, 0.28 mm thick, 4 mm pocket spacing, 3 mm pocket depth

PCB washing Tested to MIL-STD-202 Method 215 plus an additional aqueous wash. See [Doc787_PCB_Washing.pdf](#).



Shielded Power Inductors – DS1608C

Part number ¹	Inductance ² ±20% (µH)	Percent tolerance ³	Q min	DCR max (Ohms)	SRF typ (MHz)	Isat ⁴ (A)
DS1608C-102_L_	1.0	20,10	30 @ 200 kHz	0.040	250	1.4
DS1608C-152_L_	1.5	20,10	30 @ 200 kHz	0.045	125	0.93
DS1608C-222_L_	2.2	20,10	40 @ 200 kHz	0.050	120	0.92
DS1608C-332_L_	3.3	20,10	40 @ 200 kHz	0.055	120	0.75
DS1608C-472_L_	4.7	20,10	40 @ 200 kHz	0.060	105	0.58
DS1608C-682_L_	6.8	20,10	40 @ 200 kHz	0.065	50	0.58
DS1608C-822_L_	8.2	20,10	40 @ 200 kHz	0.070	42	0.47
DS1608C-103_L_	10	20,10	40 @ 200 kHz	0.075	38	0.37
DS1608C-153_L_	15	20,10	40 @ 100 kHz	0.090	33	0.31
DS1608C-223_L_	22	20,10	40 @ 100 kHz	0.11	25	0.30
DS1608C-333_L_	33	20,10	40 @ 100 kHz	0.19	20	0.30
DS1608C-473_L_	47	20,10	40 @ 100 kHz	0.23	20	0.24
DS1608C-683_L_	68	20,10	40 @ 100 kHz	0.29	15	0.17
DS1608C-104_L_	100	20,10	40 @ 100 kHz	0.48	10	0.13
DS1608C-154_L_	150	20,10	40 @ 100 kHz	0.59	9	0.10
DS1608C-224_L_	220	20,10	40 @ 100 kHz	0.77	6	0.10
DS1608C-334_L_	330	20,10	40 @ 100 kHz	1.4	5	0.07
DS1608C-474_L_	470	20,10	40 @ 100 kHz	1.8	4	0.06
DS1608C-684_L_	680	20,10	40 @ 100 kHz	2.2	3	0.055
DS1608C-105_L_	1000	20,10	40 @ 100 kHz	3.4	2	0.045
DS1608C-155_L_	1500	20,10	50 @ 100 kHz	4.2	2	0.035
DS1608C-225_L_	2200	20,10	50 @ 100 kHz	8.5	2	0.028
DS1608C-335_L_	3300	20,10	50 @ 100 kHz	11.0	1	0.024
DS1608C-475_L_	4700	20,10	50 @ 100 kHz	13.9	1	0.021
DS1608C-685_L_	6800	20,10,5	50 @ 100 kHz	25.0	1	0.019
DS1608C-106_L_	10000	20,10,5	50 @ 100 kHz	32.8	0.8	0.017

1. When ordering, please specify **tolerance**, **termination** and **packaging** codes:

DS1608C-106MLC

Tolerance: M = 20%, K = 10%, J = 5% (Table above shows stock tolerances in bold.)

Termination: L = RoHS compliant gold over nickel over moly-manganese

Special order: T = RoHS tin-silver-copper (95.5/4/0.5) or S = non-RoHS tin-lead (63/37).

Packaging: C = 7" machine-ready reel. EIA-481 embossed plastic tape (750 parts per full reel).

D = 13" machine-ready reel. EIA-481 embossed plastic tape (2500 parts per full reel). Quantities less than full reel available: in tape (not machine ready) or with leader and trailer (\$25 charge).

B = Less than full reel. In an effort to simplify our part numbering system, Coilcraft is eliminating the need for multiple packaging codes. When ordering, simply change the last letter of your part number from B to C.

2. Inductance tested at 0.1 Vrms, 100 kHz, 0 Adc.

3. Tolerances in bold are stocked for immediate shipment.

4. DC current at which the inductance drops 30% (typ.) from its value without current.

6. Electrical specifications at 25°C.

Refer to Doc 362 "Soldering Surface Mount Components" before soldering.



www.coilcraft.com

US +1-847-639-6400 sales@coilcraft.com

UK +44-1236-730595 sales@coilcraft-europe.com

Taiwan +886-2-2264 3646 sales@coilcraft.com.tw

China +86-21-6218 8074 sales@coilcraft.com.cn

Singapore + 65-6484 8412 sales@coilcraft.com.sg

Document 186-2 Revised 02/07/14

© Coilcraft Inc. 2021

This product may not be used in medical or high risk applications without prior Coilcraft approval. Specification subject to change without notice. Please check web site for latest information.



Shielded Power Inductors – DS1608C

Typical L vs Frequency

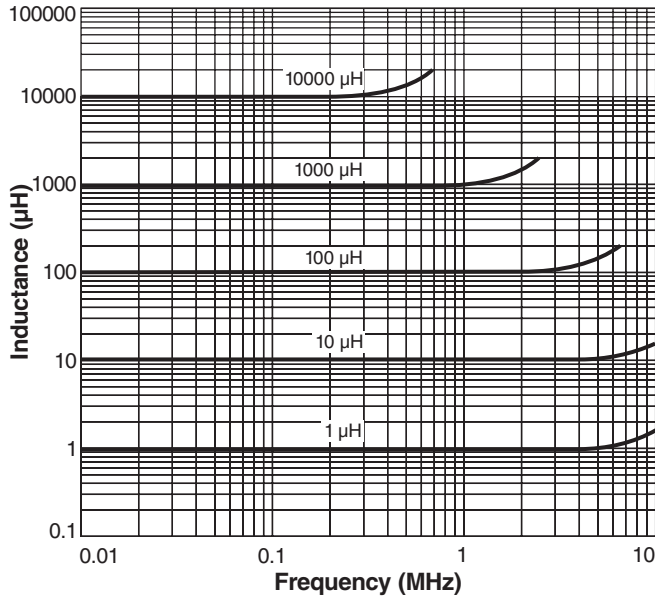

Typical L vs Current

